



Air to water heat pumps

# Technical Manual

## Models

SHP290 21 kW

SHP290 23 kW

SHP290 25 kW

SHP290 27 kW



This manual has been created for informative purpose. The company declines any responsibility for the results of any projecting or any installation based on the explanations and/or on the technical specifications provided in this manual. It is besides forbidden the reproduction under any form of the texts of the figures contained in this manual. The data in this manual are not binding and may be changed by the manufacturer without prior notice. Even partial reproduction PROHIBITED © Copyright - EOGB Energy Products Ltd

01	03-2024	EG	AL.B	Update of performance tables, some correction and update of GWP. Added new accessories and minimum performace tables.
00	10-2023	AL.B	AR	First issue
<b>Rev</b>	<b>Date</b>	<b>Author</b>	<b>Supervisor</b>	<b>Notes</b>
<b>Catalogo / Catalogue / Katalog / Catalogue</b>				<b>Serie / Series / Serie / Serie / Série</b>
<b>BTE02060120000_01</b>				<b>INVERTER AIR/WATER HEAT PUMPS WITH AXIAL FANS</b>

**Contents**

1. DESCRIPTION OF UNIT AND TECHNICAL SPECIFICATIONS ..... 6

1.1 FRAMEWORK ..... 6

1.2 COMPRESSORS ..... 6

1.3 AIR SIDE HEAT EXCHANGER ..... 6

1.4 UTILITY SIDE HEAT EXCHANGER..... 6

1.5 FAN (EC) ..... 6

1.6 COOLING CIRCUIT..... 6

1.7 ELECTRICAL PANEL ..... 8

1.8 CONTROL SYSTEM ..... 8

1.9 CONTROL AND PROTECTIVE DEVICES..... 8

1.10 HYDRAULIC CIRCUIT ..... 8

2. DESCRIPTION OF VERSIONS AND ACCESSORIES..... 8

2.1 LIST OF ACCESSORIES..... 9

2.2 DESCRIPTION OF ACCESSORIES..... 10

2.2.1 Component supplied as standard..... 10

2.2.2 Factory-fitted accessories ..... 11

2.2.3 Accessories supplied separately ..... 11

2.3 SAFETY RULES FOR R290 UNITS TRANSPORT AND STORAGE ..... 12

3. INSTALLATION ..... 13

3.1 GENERAL ..... 13

3.2 TRANSPORT AND STORAGE TEMPERATURE LIMITS ..... 14

3.3 LIFTING AND HANDLING ..... 14

3.3.1 Lifting mode ..... 15

3.4 UNIT DIMENSIONS, PLUMBING CONNECTIONS AND WEIGHTS ..... 15

3.4.1 Net dimensions and with packaging..... 15

3.4.2 Weights ..... 16

3.4.3 Positioning the centre of gravity and vibration dampers ..... 16

3.5 POSITIONING AND MINIMUM TECHNICAL CLEARANCES..... 17

3.6 DANGER AND SAFETY ZONES ..... 19

3.6.1 Free-field ground installation ..... 20

3.6.2 Ground installation in front of a wall..... 20

3.6.3 Ground installation in a corner..... 21

3.6.4 Flat floor installation ..... 22

3.6.5 Multiple installation ..... 22

3.7 PLUMBING CONNECTIONS ..... 22

3.7.1 Characteristics of the circuit water..... 23

3.7.2 Typical plumbing diagram ..... 24

3.7.3 Minimum water content and hydraulic circuit volumes..... 24

3.7.4 Plumbing diagram inside unit..... 24

3.7.5 System load ..... 26

3.7.6 System discharge ..... 26

3.7.7 Deaerator ..... 26

4. GENERAL TECHNICAL DATA ..... 27

4.1 ELECTRICAL AND AUXILIARY DATA..... 29

5. CORRECTION FACTORS..... 29

5.1 CORRECTION FACTORS FOR USE OF GLYCOL WATER MIXTURE..... 29

5.2 SCALING CORRECTION FACTORS..... 29

5.3 INSTRUMENTATION CALIBRATIONS AND PROTECTIONS..... 29

5.4 CORRECTION FACTORS ACCORDING TO ALTITUDE ..... 29

6. HYDRONIC UNIT DATA..... 30

6.1 USEFUL HEADS..... 30

6.2 CIRCULATOR CURVES ..... 30

6.3 ACCESSORY PRESSURE DROPS Y-FILTER, DIRT DEFLECTOR AND 3-WAY VALVE . 31

7. SOUND EMISSIONS..... 33

7.1 FULL LOAD UNITS ..... 33

7.2 PARTIAL LOAD UNIT ..... 34

8. OPERATING LIMITS..... 35

8.1 EVAPORATOR WATER FLOW ..... 35

8.2 COLD WATER PRODUCTION (SUMMER MODE) ..... 35

8.3 HOT WATER PRODUCTION (WINTER MODE)..... 35

8.4 AMBIENT AIR TEMPERATURE AND SUMMARY TABLE ..... 35

8.5 ENVELOPE IN HEATING AND COOLING..... 36

8.6 ENVELOPE IN DHW ..... 37

9. PERFORMANCE TABLES..... 38

9.1 UNIT HEATING..... 38

9.2 COOLING ..... 40

9.3 DOMESTIC HOT WATER..... 41

9.4 PERFORMANCE TABLES AT MINIMUM CAPACITY..... 41

10. SEASONAL PERFORMANCE AT DIFFERENT TEMPERATURE LEVELS ..... 43

11. DATA FOR THE ENERGY CERTIFICATION OF BUILDINGS ACCORDING TO UNI/TS 11300-4 FOR HEAT PUMPS ..... 44

11.1 EER DATA TO CALCULATE THE ENERGY PERFORMANCE OF BUILDINGS, ACCORDING TO UNI/TS 11300-3 ..... 46

12. REFRIGERANT SAFETY DATA SHEET ..... 48

### 1. DESCRIPTION OF UNIT AND TECHNICAL SPECIFICATIONS

The SHP290 heat pumps were designed for outdoor use in residential and commercial applications only: They are extremely versatile and prepared for heat pump operation with hot water production for ambient heating and for sanitary use at a temperature of 78 °C. The refrigerant employed is R290 gas, which, thanks to its low GWP, ensures a long term solution in terms of efficiency and environmental sustainability. Use of the INVERTER-controlled brushless compressor technology, coupled with electronic expansion valve, circulator pump and variable speed fan ensures excellent performance, due to the optimisation of the specific consumption and the high modulating capacity, which in turn translate into high COP, EER, SCOP and SEER values.

#### 1.1 FRAMEWORK

All units of the range are manufactured from continuously hot-dip galvanised sheet steel and painted with polyurethane powders in an oven at 180°C to ensure the best weather resistance. The frame is self-supporting with removable panels for easier inspection and maintenance of the inner components. All screws and rivets for outdoor installation are in galvanised steel.

#### 1.2 COMPRESSORS

The DC inverter compressor is scroll type, are designed to operate with R290, equipped with thermal protection and mounted on rubber vibration dampers. The compressors are installed in a compartment separated from the air flow to reduce noise. They are also equipped with crankcase heater to prevent oil dilution and consequently galling. The compressors can be inspected by removing the side and front panels of the unit, so that they can be serviced even with the units running.

#### 1.3 AIR SIDE HEAT EXCHANGER

The air heat exchangers are made of copper pipes and pre-painted aluminium fins. The pipes are mechanically expanded into aluminium fins to increase the thermal exchange factor. The shape of these exchangers allows a low air side pressure drops and therefore fans can run at low speed (thus reducing unit noise). As optional the coils can be supplied with a "SILVER LINE" to allow greater resistance to acidity and salt spray resulting in increased hydrophilic ability and performance compared to a battery with simple aluminium fins. The air side exchangers are designed to minimise the refrigerant gas charge.

#### 1.4 UTILITY SIDE HEAT EXCHANGER

The utility heat exchangers are the brazed plate type, made of stainless steel AISI 304, insulated at the factory with closed cell material. They can be equipped with anti-freeze electric heater (optional KA accessory). Each evaporator is protected by a temperature sensor used as an antifreeze protective probe which activates the circulator, even when the machine is switched off, if the conditions imposed on the control occur.

#### 1.5 FAN (EC)

The fans are made of plastic, the axial type with airfoil blades. They are all statically and dynamically balanced and are supplied complete with protective grid. All electric motors used are brushless modulating to optimise the evaporation/condensation pressure in summer/winter operation so as to allow the correct operation of the machine. The motors are directly coupled and equipped with integrated thermal protection with IP54 rating.

#### 1.6 COOLING CIRCUIT

The cooling circuit is made with components of leading international companies and in compliance with UNI EN standard 13134 on braze-welding procedures. The coolant is the new R290 (GWP equal to 0,02) ecological gas. The basic version of the cooling circuit includes: 4-way cycle reversing valve, electronic expansion valve, liquid separator, liquid receiver, safety device (high-pressure switch), pressure transducers to carefully measure evaporation and condensing pressure, dehydrating filter to prevent clogging of the lamination valve, liquid flow indicator and presence of moisture. The suction line is thermally insulated with flexible, closed-cell elastomeric foam. A pressure test is performed to detect any potential leakage and the unit is supplied already charged with the optimal amount of gas for proper functioning.

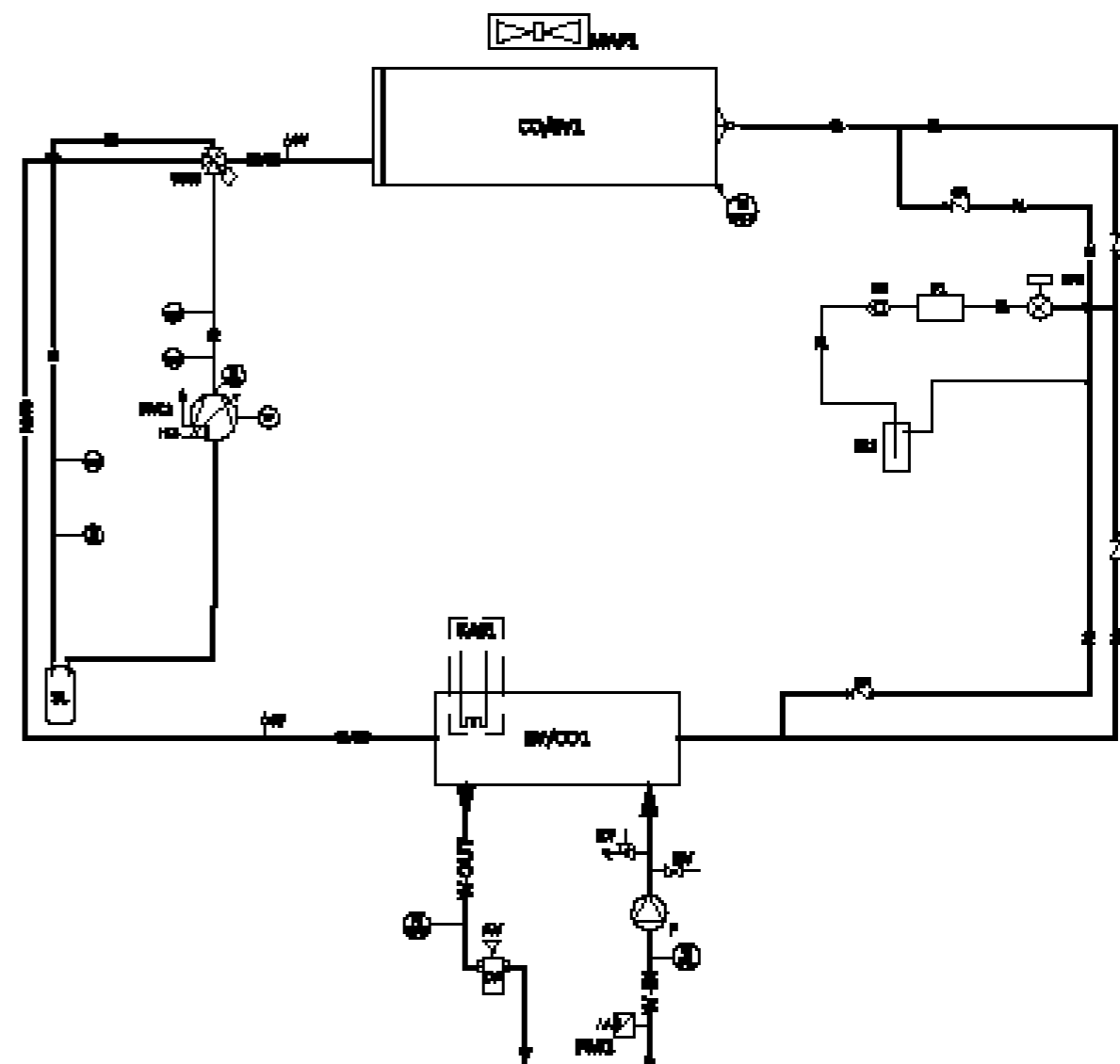

LEGEND					
ACRONYM	NUM.	DESCRIPTION	ACRONYM	NUM.	DESCRIPTION
INVC	1	VARIABLE SPED COMPRESSOR	W-OUT		SYSTEM WATER OUTLET LINE
CO/EV	1	CONDENSER (IN CHILLER OPERATION)	W-IN		SYSTEM WATER INLET LINE
EV/CO	1	EVAPORATOR (IN CHILLER OPERATION)	TRH	1	HIGH PRESSURE TRANSDUCER
EEV	1	ELECTRONIC EXPANSION VALVE	TRL	2	LOW PRESSURE TRANSDUCER
Y4W	1	4-WAY CYCLE REVERSING VALVE	TE EXT	1	OUTDOOR AIR TEMPERATURE PROBE
TH		SAFETY THERMOSTAT	TE SD	1	SUCTION LINE TEMPERATURE PROBE
F	1	FILTER	TE DT	1	COMPRESSOR DISCHARGE TEMPERATURE PROBE
SV		FILLING CONNECTION	PSH	1	HIGH-PRESSURE SWITCH
HC	1	CRANKCASE HEATER	TE IN	1	USER INPUT TEMPERATURE PROBE
MAF	1	AXIAL FAN	TE OUT	1	USER OUTLET TEMPERATURE PROBE
CV	1,2,3,4	NON-RETURN VALVE	DV		DRAIN TAP
SL		LIQUID SEPARATOR	RV		SAFETY VALVE
RS		SUCTION LINE	FM	1	FLOWMETR
RD		DISCHARGE LINE	P		ELECTRONIC CIRCULATOR
RL		LIQUID LINE	AV		AUTOMATIC AIR VENT VALVE
RD/RS		DISCHARGE/SUCTION LINE	DA		DEAERATOR
RS/RD		SUCTION/DISCHARGE LINE	KAS	1	PLATE EXCHANGER ANTIFREEZE HEATER
SG	1	MOISTURE INDICATOR	LR	1	LIQUID RECEIVER

### 1.7 ELECTRICAL PANEL

The electric panel is designed in compliance with current European standards. The electric panel can be accessed by removing the cover on the unit using a specific tool. The electric panel has an IPX4 protection rating. The panel is also supplied with an auxiliary board for electrical connections and utilities. The auxiliary board has digital inputs with voltage-free contact for:

- ON-OFF remoto.
- Summer/winter mode.
- Double set-point control.

There are also analogue inputs for:

- Domestic hot water sensor.
- Storage sensor.

Below listed the digital inputs (max. voltage available for input: 0,5 A):

- Machine stall alarm.
- 3-way valve for Domestic Hot Water control.
- Double set-point control.

The system is pre-fitted with connectivity arrangement for ModBus RTU RS-485 monitoring and 12 VAC supply i-CR wall-mounted controller.

### 1.8 CONTROL SYSTEM

All SHP290 units are equipped with microprocessor with overheating control logic by means of an electronic thermostatic valve managed according to the signals sent by the pressure transducers. The CPU also controls the following functions: water temperature control, antifreeze protection, compressor timing, alarm reset, alarm management and operating LEDs. The control system, with the INVERTER technology and on board sensors, monitors and continuously adapts the performance of the inverter compressor, of the circulator and of the fan.

### 1.9 CONTROL AND PROTECTIVE DEVICES

All the units are standard supplied with the following control and protective devices: return water temperature sensor, installed on water return pipe from the system, working and antifreeze probe installed on the water discharge pipe to the system, high pressure transducer, low pressure transducer, temperature probes on both the compressor's suction and discharge lines, compressor thermal protection, fan thermal protection, water side flowmeter protecting the evaporator, high pressure switch.

### 1.10 HYDRAULIC CIRCUIT

SHP290 chillers are supplied with a built-in water circuit which includes: modulating circulator with high-efficiency brushless motor (EEI≤0,23), suitable for the use of chilled water and managed directly by the machine's controller, plate heat exchanger, flowmeter, safety valve (6 bar) to be connected to an exhaust and deaerator system with air release valve.

## 2. DESCRIPTION OF VERSIONS AND ACCESSORIES

### 2.1 VERSIONS

SHP290 reversible heat pump with built-in hydronic unit (safety valve, modulating circulator, flowmeter, filling/drain valve).

Available models: 21 kW, 23 kW, 25 kW & 27 kW The power supply is three-phase.

The unit code consists of the following elements:

- 7 fixed digits.
- The symbol # as separator.
- 10 variable digits (fields) identifying the sizes, power supply and factory mounted accessories.
- 2 variable digits (MC field) which identify the i-290 series in any customisations.

0112822#(RV)(CT1)(SIL)(KA)(TR)(RP)(MB)(AC1)(MC)

<b>Order code</b>	0112822#	SHP290
<b>Configuration</b>	57	Reversible heat pump
<b>Size</b>	24	21 kW
	40	23 kW
	41	25 kW
	42	27 kW
-	0	-
<b>Antifreeze kit</b>	0	-
	1	With antifreeze kit (KA)
	7	Base resistance (KA3)
<b>Heat exchanger treatment</b>	0	-
	8	With Silverline treatment (TR2)
	9	With Silverline and panels treatment (TR2C4)
<b>Protection grids</b>	0	-
	1	With protection grids (RP)
<b>Modbus</b>	0	-
	1	Modbus connectivity (CM)
-	0	-
-	01	-



**CAUTION: The antifreeze kit is a factory mounted accessory. It is not possible to install it later.**

### 2.1 LIST OF ACCESSORIES

The available accessories for the SHP290 heat pumps are listed below.

	Accessory	Standard	Factory-fitted	Supplied separately
AG - Vibration damper kit	x			x
KA - Antifreeze kit	x		x	
KA3 - Antifreeze kit (base frame only)	x		x	
TR2 - Coils anticorrosion treatment	x		x	
TR2C4 - Coils and panels anticorrosion treatment	x		x	
RP - Coils protection grids	x		x	x
FY - Y-filter	x			x
Filling /drain valve		x	x	
Water side safety valve		x	x	
VDIS3 - Diverter valve (1"1/4) Kvs 20,8	x			x
Electronic throttling valve		x	x	
SAS - Domestic hot water probe / System remote probe	x			x
SPS - Solar panel probe for GI3	x			x
Flowmeter (flow presence signal)		x	x	
Hi-TV415 - Multifunctional touch screen remote control	x			x
i-CR - Wall-mounted remote control		x	x	
GI3 - External system management module	x			x
FD - Dirt separator	x			x
Deaerator		x	x	
Electronic circulator		x	x	
Remote on/off voltage-free contact		x	x	
BMS connectivity arrangement - ModBus protocol included (CM)	x		x	x
USB/RS485 Serial converter (ISK)	x			x
Local LAN/WiFi converter (LNC)	x			x
OpenVPN LAN/Wifi 3G Remote Converter (OVPN)	x			x

	Accessory	Standard	Factory-fitted	Supplied separately
Editing the dynamic set-point - climate curve (via external air probe fitted in the unit)		x		x
Dry contact for summer/winter selection		x		x
Machine block signal		x	x	
Enabling maximum Hz (*)		x		x
Enabling minimum Hz (*)		x	x	
Digital input for double set-point		x		x

(\*) Functions can be enabled as an alternative.

## 2.2 DESCRIPTION OF ACCESSORIES

### 2.2.1 Component supplied as standard

**Electronic circulator** - standard on the unit, electronically controlled and high efficiency.

**Flowmeter (flow presence signal)** – this device monitors and signals water circulation in the plate heat exchanger. This component is essential because it switches off and secures the unit preventing the formation of ice.

**Electronic throttling valve** – expansion valve, designed for the control and continuous regulation of the amount of refrigerant entering the evaporator. To optimise consumption, changes in thermal load can be monitored quickly.

**Water side safety valve** - valve installed on the hydraulic circuit to control overpressure - setting 6 bar.

**Filling / drain valve** - there is always a service valve in the unit that is used to fill/discharge the amount of water in the system or adjust the glycol percentage.

**Deaerator** - component to continuously capture and expel air and any other gases dissolved in the water in the hydraulic circuit. The removal efficiency of this device is very high, allowing the elimination of non-condensable gases present in the circuits down to microbubble level.

**i-CR - wall-mounted remote control** - Modbus remote control with negative LCD and capacitive keys. The device is to be used as a remote machine keyboard with local temperature detection, replicating the functionality of the on-board control.

**Remote on/off voltage-free contact** – contact on the auxiliary board which allows the unit to be switched on and off.

**Changing the dynamic set-point - climate curve (via the outside air probe in the unit)** - the controller allows the set-point to be changed by adding a value according to the temperature of the outside air probe.

**Dry contact for Summer/Winter selection** – possibility to remotely control the heating or cooling mode of operation of the heat pump.

**Machine block signalling** - control system signalling of locked unit (can be reset manually). Alternatively, one of the following functions can be activated (contact after-sales service):

- Alarm signalling;
- Defrosting signalling;
- Compressor running signalling;
- Season signalling;
- System integration resistor management;
- Sanitary integration resistor management;

**Enabling minimum Hz** - With the activation of this function (which must be done following the procedure described in the control manual) the unit will reduce the power consumption by approximately 10% of the nominal reference value, resulting in a reduction in capacity. Alternative function at maximum Hz.

**Enabling maximum Hz** - With the activation of this function (which must be enabled by the after-sales service) the unit will increase the capacity by approximately 10% over the reference nominal value, resulting in an increase in power consumption. Alternative function at minimum Hz.

**Digital input for double set-point** - input to change the set point.

**Fan silent mode** - Digital input that can be activated by external contact, allowing the sound power level to be reduced by acting on the ventilation. The mode is particularly suitable during night operation. Below are the decreases in capacity and sound power level when the fan silent mode function is active. The reduction refers to test condition (3) of the technical data tables; the value is determined on the basis of measurements carried out in accordance with UNI EN ISO 9614-1, in compliance with the requirements of Eurovent certification.

Model SHP290	Yield reduction factor [-] A7W35	Sound power level reduction [dB(A)]
21 kW	0,989	-1
23 kW	0,981	-1
25 kW	0,978	-1
27 kW	0,972	-1

### 2.2.2 Factory-fitted accessories

**KA - Antifreeze kit** - It involves the use of a self-heating cable that is fixed to the base of the unit in the vicinity of the condensation coil and a PET resistance placed on the face of the plate heat exchanger.

**KA3 - Antifreeze kit (base frame only)** - This only involves the use of a self-heating cable that is applied to the base of the unit near the condensation coil.

**TR2 - Coil anticorrosion treatment** – With the treatment the coil becomes flexible to withstand contractions and thermal expansions, it is mechanically resistant, UV-protected and dirt repellent. Heat transmission losses are very low. The treatment ensures coil protection in all environmental conditions: from marine to rural settings, from industrial to urban areas.

For specific cleaning instructions for coils treated in this way, please refer to the chapter in the user-installer manual 'Cleaning of Corrosion Treated Coils'.

The treatment withstands 6000 h according to ASTM B117.

**TR2C4 - Anti-corrosion treatment** - provides a TR2-type coil treatment (as described above) and, in addition, the hot-dip galvanized steel panels are painted according to UNI EN 12944 for machine installations in C4H environments. The external screws are made of AISI304 class A2 material.

Excluded from the treatment are the fan (blades and external protection grille) and the galvanized sheets inside the machine (panel box and inductances).

**BMS connectivity arrangement - ModBus protocol included (CM)** – accessory to connect the unit to external controllers via serial cable with RS-485 electric standard and ModBus RTU protocol. This accessory can also be activated after sales.

**RP - Battery protection grids** - wire mesh to prevent the intrusion of foreign bodies inside the battery and to protect the battery from accidental contact with things or people (can also be ordered as a separate accessory).

### 2.2.3 Accessories supplied separately

**AG - Vibration damper kit** – they prevent transmitting vibrations to the structure; they must be fitted into the appropriate holes underneath the unit.

**GI3 - External plant management module** - allows management of the following functions:

- Recirculation circulator management.
- System-side mixing valve management.
- Solar thermal integration management.

**VDIS3 - Diverter valve** – 3-way motorised ball valve Kvs 20.8, connections F 1" 1/4 complete with servo-control.

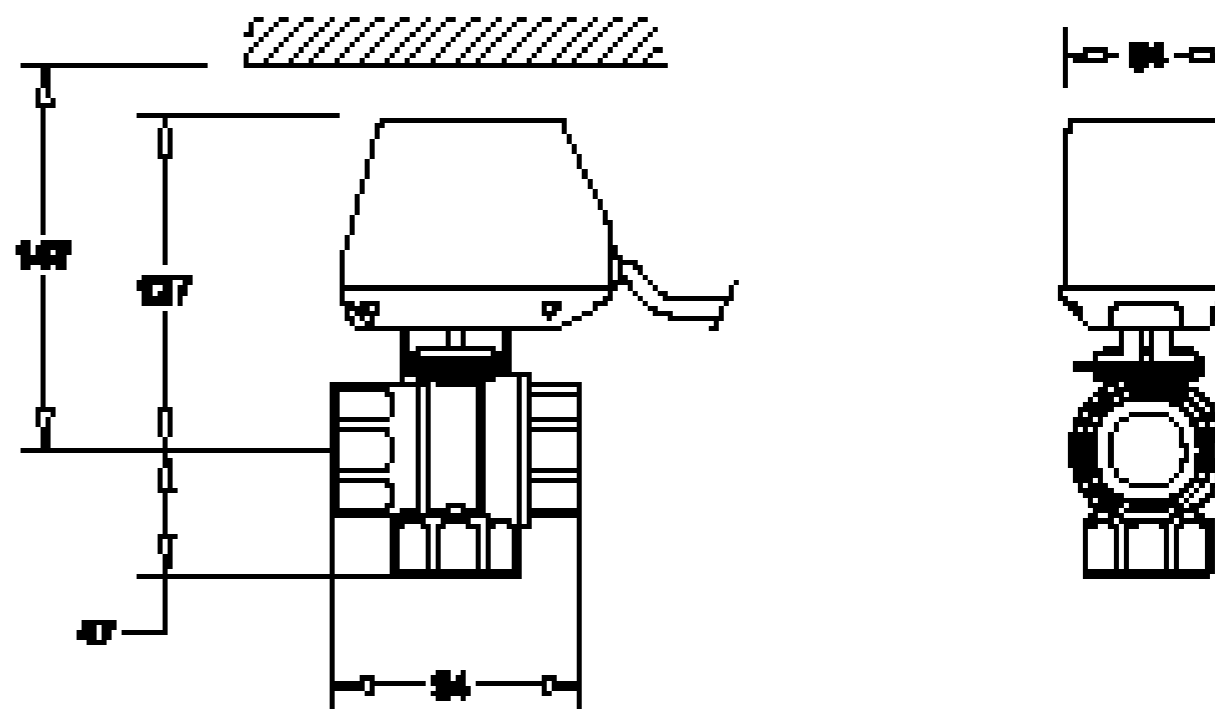

Permitted substances: water from 0°C to +110°C.  
 Maximum differential pressure: 6 bar  
 Please refer to the document enclosed with the product for more information.



**CAUTION:** Install the valve outside the danger and safety zones indicated in Chapter 3.6.

**FY - Y-filter** – contains a stainless steel mesh sieve (500 µm filtration) that collects solids in the water. Filtration prevents clogging and/or damage to devices installed downstream of the filter. Alternatively, it is possible to install a dirt separator which guarantees a filtration degree of no more than 1 mm (in this case, it is no longer necessary to install the Y-filter).

**SPS - Solar panel probe for GI3** – probe required to measure the temperature of the solar panels if the unit is integrated with a solar thermal system.

**FD - Dirt separator** – blocks and retains the heaviest impurities in the hydraulic circuit, which are captured by a synthetic filtering grid and collected in a settling chamber. A magnetic device placed inside the body of the dirt separator also allows ferromagnetic particles to be intercepted.

Model SHP290	Code
21 kW, 23 kW, 25 kW & 27 kW	0119100081

The pressure drops of the accessory as a function of the flow rate are shown:

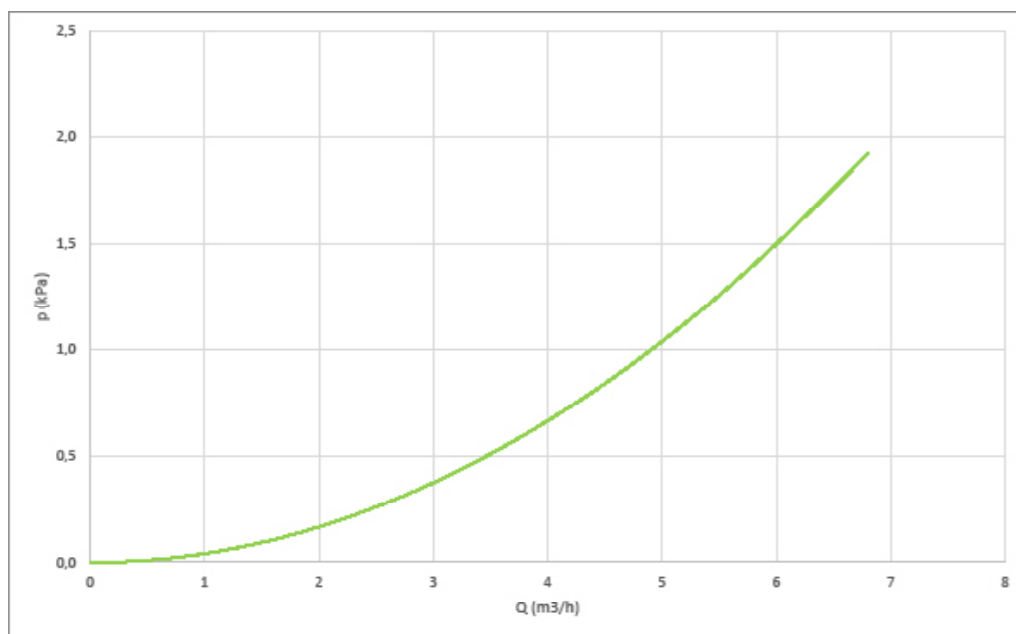

p [kPa]	Pressure drop
Q [m³/h]	Water flow rate

**SAS - Domestic hot water probe / System remote probe** – In some system solutions (e.g. heat pump in parallel to boiler on same hydronic circuit and shut off diverter valve) it might be necessary to enable a system temperature probe so that the machine controller can correctly process the control. The system remote probe controls the temperature of the heat pump only during the compressor start-up phase. Shutdown is managed by the probe on the heat pump delivery line.

**Hi-TV415 - Multi-purpose touch screen remote control** – touch screen remote control for centralised management of a chiller/heat pump network. It includes humidity and temperature sensors for the thermal hygrometric analysis of the environment and for the management of the double set point for radiant floor heating systems that use a dehumidification system.

**ISK - USB/RS485 Serial converter** – interface device capable of reading and writing control registers via the RS485 standard and converting it to a USB port that can be connected to any supervisory system.

**LNC - Lan-Wifi Router** – device that allows the unit to be connected to a local network via Ethernet cable or Wifi coverage for internal monitoring.

**OVPN - Router Lan-Wifi 3G con tunnel VPN** – device that allows the unit to be connected remotely with industrial routers using the secure OPENVPN service. device that allows the unit to be connected to a local network via Ethernet cable or Wifi coverage for internal monitoring.

## 2.3 SAFETY RULES FOR R290 UNITS TRANSPORT AND STORAGE

Before opening the unit's packaging, ensure there are no gas leaks in the ambient with an appropriate gas detector. Check that there are no ignition sources near the unit.

No smoking near the unit.

Transport and storage must be performed in accordance with the national regulations in force. Specifically, according to ADR provisions, the total maximum quantity by transport unit in terms of net mass for flammable gases is 333 kg. In addition, for road transport, use vehicles that are preferably open or equipped with a ventilation system and operated by trained personnel.

For prerequisites on the transport by sea of equipment loaded with flammable refrigerant refer to the International Maritime Dangerous Goods Code (IMDG), and for transport by air check the regulations prescribed by the International Air Transport Organisation (IATA).

If it is necessary to store the unit for medium to long periods, please observe the following precautions:

- if storage is in a closed location, leave the machine in a dedicated place that is always dry, cool, well ventilated and protected from possible ignition sources, direct sunlight or other heat sources. It is also recommended to use one flammable gas detection sensor every 36-40 m<sup>2</sup>. Please refer to national regulations;
- if storage is carried out in an open area, observe the minimum safety distances from drains, cisterns, sewers and other underground areas, in compliance with the national regulations in force;
- do not remove covers and packaging;
- ensure that all panels are correctly mounted;
- do not obstruct the openings and holes made in the machine panels;
- avoid cleaning the unit with aggressive detergents or chemicals;
- it is advisable to remove any heating water inside the unit to prevent possible corrosion or, in cold climates, damage to components caused by freezing.



**CAUTION:** During transport and storage of the unit, beware of possible refrigerant gas leaks that could start a fire.

## 3. INSTALLATION



**CAUTION:** All the operation described below must be done by **QUALIFIED PERSONNEL** only (IEC 60335-2-40 Annex HH). Before any operation on the unit, make sure that power supply is disconnected. Also ensure, by means of appropriate locks, that the power supply cannot be accidentally switched on again until all operations have been completed.

### 3.1 GENERAL

When installing or when work is to be carried out on the refrigeration circuit, it is necessary to scrupulously comply with the regulations in this manual, observe the indications on the unit and in any case apply all necessary precautions. Failure of this may lead to dangerous situations.



After receiving the unit, immediately check its integrity. The unit left the factory in perfect condition; any damage must be immediately reported to the carrier and recorded on the Delivery Note before signing it.

The company must be informed, within 8 days, of the extent of the damage. The customer should prepare a written statement of any severe damage.



The units are designed to be installed outdoors. Under no circumstances should the outdoor ambient temperature exceed 46°C when the unit is not in operation. Above this value, the unit is no longer covered by current pressure equipment safety regulations.



The installation place must be without any fire risks. All necessary measures must therefore be taken to prevent the risk of fire at the installation site (see Chapter 3.6 for more details). The device must not be placed in the vicinity of open flames, ignition sources or heat sources. The wall of the buildings near the unit must have an adequate fire resistance class, in order to contain any fire that may develop inside the rooms. However, it is recommended to place a fire extinguisher near the unit.



The unit must be installed in order to allow maintenance and repair. The warranty does not cover costs for platforms or other lifting equipment needed for any interventions.



All the maintenance operations and tests must be done by **QUALIFIED PERSONNEL** (IEC 60335-2-40 Annex HH). All equipment used during maintenance operations must be compatible with the refrigerant gas R290.













Before any operation on the unit, make sure that the power supply is disconnected and cannot be switched on again accidentally. After disconnecting the power supply from the unit, wait at least 5 minutes before performing any operation on the machine to allow the condenser to discharge.



Do not use equipment to speed up the defrost process or for cleaning except for those recommended by the manufacturer.



The appliance must be placed outside, in a place without continuously operating ignition sources (e.g. open flames, an operating gas appliance or electric heater). Refer to Chapter 3.6.

	Cable ducts and electrical conduits to the machine must not contain potential ignition sources.
	Do not perforate or burn. Do not make mechanical modifications to the unit.
	There are some moving parts inside the unit. Use extreme caution when working near them, even if the power supply is disconnected. In particular, pay attention to the fan blades when removing the front protective grilles. Do not touch or insert any objects into the moving parts.
	The compressor heads and discharge pipework are at quite high temperatures. The pipes on the suction side of the compressor, can reach very low temperatures. Uninsulated pipes can cause burns or freezer burns: only handle these components when their temperature is close to ambient.
	Be particularly careful when working near batteries. Aluminium fins are very sharp and can cause serious injury.
	After the maintenance operations, close the panels by fixing them with screws.
	After maintenance or replacement of components, reconnect the cables in the same position as in the factory.
	Routine maintenance operations can be carried out with the machine charged, while in the case of extraordinary operations, repairs or replacement of components and heavy work in the vicinity of the machine (e.g. construction sites), drain the machine of coolant gas and move it to a safe area if necessary (in accordance with Chapter 3.6).
	Insulating materials are not self-extinguishing: remove them when working on the unit, if necessary.
	Do not remove, replace or make illegible the adhesive labels on the unit and packaging. Do not cover the labels after installation of the unit.

### 3.2 TRANSPORT AND STORAGE TEMPERATURE LIMITS

Minimum storage temperature [°C]	-10 °C
Maximum storage temperature [°C]	+50 °C

### 3.3 LIFTING AND HANDLING

The handling must be performed by qualified personnel, properly equipped with appropriate tools to the weight and the encumbrance of the unit, in compliance with safety regulations of accident preventing. It is recommended:

1. Check the weight on unit technical label or on table of technical data;
2. Check moving the unit there are no disconnected paths, ramps, steps, doors that could affect the movement and damage the unit;
3. Check that the unit remains horizontal when moving;
4. During handling, do not carry out abrupt and sudden manoeuvres in order to not destabilise the unit;
5. Before handling the unit, check that the equipment is suitable for lifting and preserving the integrity of the unit;
6. Perform lifting only by one of the listed procedures;
7. Before starting handling make sure, the unit is in stable equilibrium.

Note that the weight of the unit is concentrated more on the side of the refrigeration circuit: take into consideration the weight distribution of the machine when transporting it manually with ropes, in order not to lift excessive loads and avoid damage or personal injury. It is recommended to remove the packaging only after the machine has been placed in the actual installation location. Dispose of the different packaging materials in accordance with national regulations.

	Before commissioning, carefully inspect the unit and packaging for damage or refrigerant leakage.
---	---

	Do not proceed with the start-up of the unit if damage was found during transport. Immediately inform the Company of the problem. The company is not liable for any damage to the product caused by handling and transporting the unit in a manner not in accordance with this manual and the regulations in force.
---	---

### 3.3.1 Lifting mode

Following lifting modes are allowed:

- forklift truck;
- ropes / bands.

Make sure to tension the lifting ropes gradually and check their correct positioning.

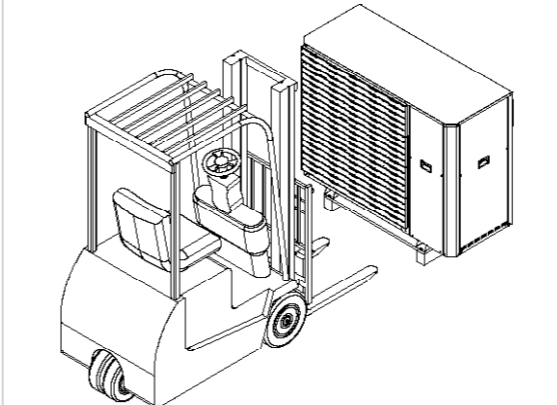
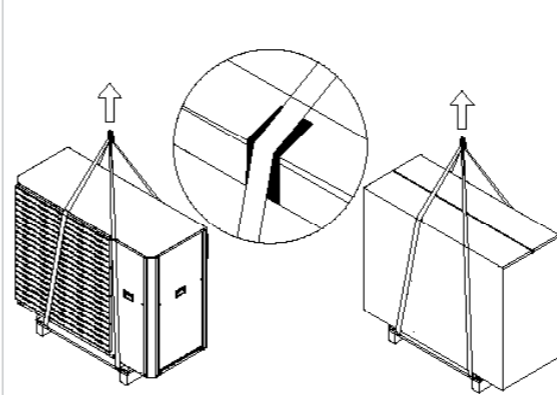
	Lifting through forklift truck.
	Lifting with ropes / bands.

### 3.4 UNIT DIMENSIONS, PLUMBING CONNECTIONS AND WEIGHTS

#### 3.4.1 Net dimensions and with packaging

Model SHP290	Length [mm]	Width [mm]	Height [mm]	Plumbing connections IN/OUT	Dimensions with packaging (length x width x height)[mm]
21 kW / 23 kW / 25 kW / 27 kW	1610	710	1270	1" 1/4 G	1780x820x1430

IN/OUT: 1" 1/4 G  
E: power supply input.

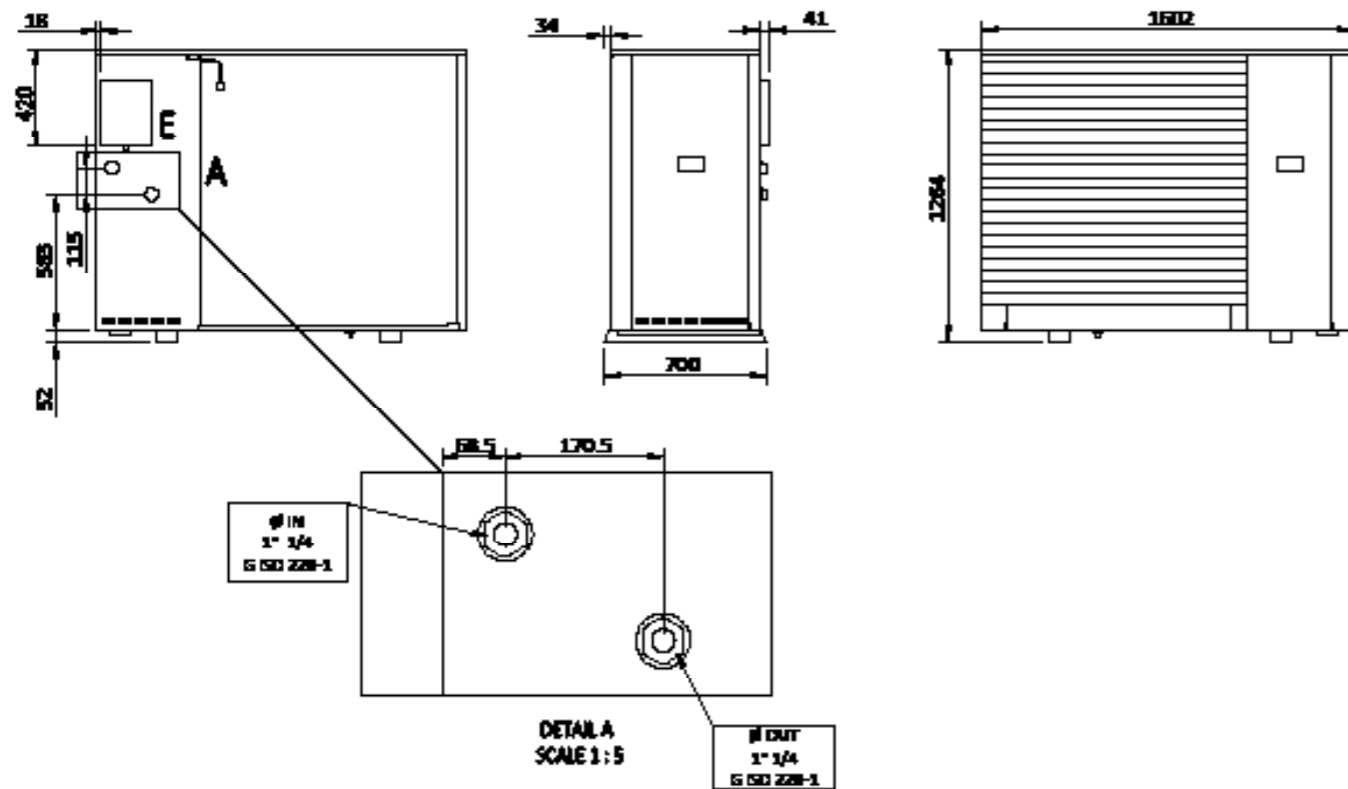

3.4.2 Weights

Model SHP290	Shipping weight [kg]	Operating weight [kg]
21 kW	276	254
23 kW	276	254
25 kW	285	264
27 kW	285	264

3.4.3 Positioning the centre of gravity and vibration dampers

The position of the centre of gravity of each machine is indicated in the tables, with reference to the dimensions shown in the image.

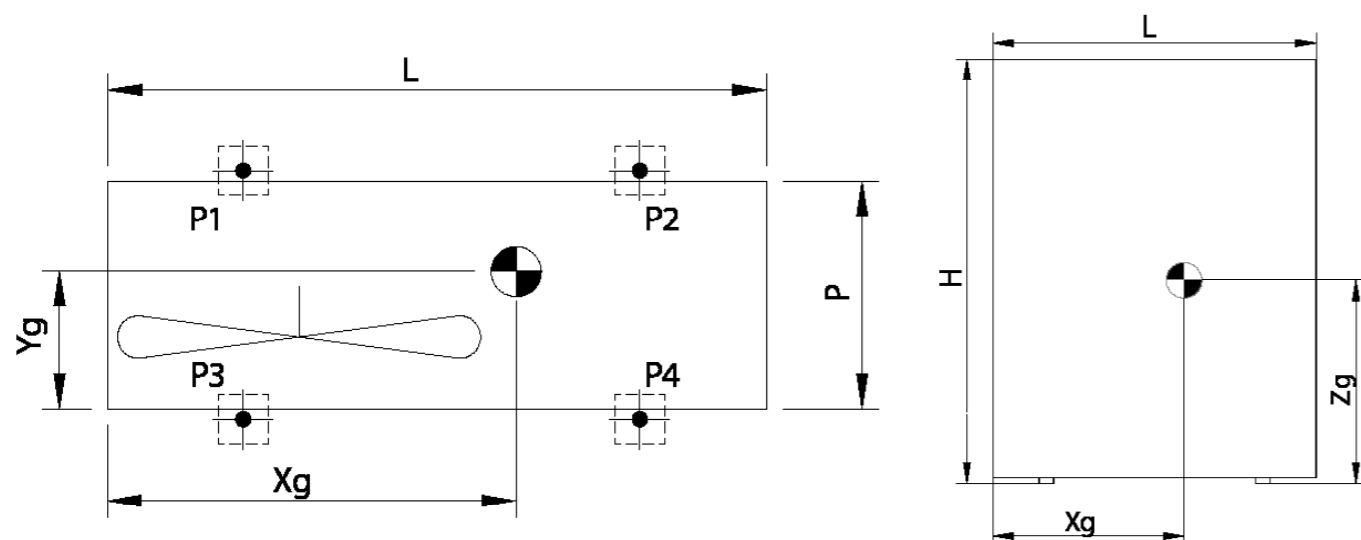

Models SHP290	L [mm]	P [mm]	H [mm]	Xg [mm]	Yg [mm]	Zg [mm]
21 kW	1610	710	1270	810	395	655
23 kW	1610	710	1270	810	395	655
25 kW	1610	710	1270	800	410	655
27 kW	1610	710	1270	800	410	655

The positions provided for the installation of vibration dampers for each type of machine are shown in the pictures below.

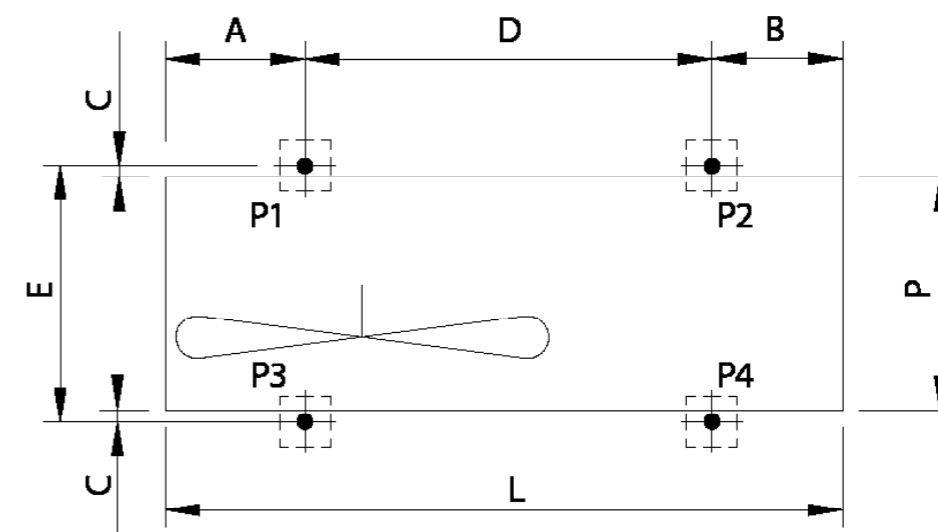

Models SHP290	A [mm]	B [mm]	C [mm]	D [mm]	E [mm]
21 kW / 23 kW / 25 kW / 27 kW	331	308,5	30	962,5	640

3.5 POSITIONING AND MINIMUM TECHNICAL CLEARANCES

All models of SHP290 are designed and constructed for outdoor installations. The company is not liable for any damage to property, animals and/or persons resulting from failure to comply with the instructions on installing the unit described in this manual. It is advisable to create an adequately sized support base for the unit. The units transmit a small amount of vibrations to the ground: however, it is advisable to place anti-vibration mounts between the base frame and the supporting surface. It is preferable to install the unit away from places sensitive to noise and vibration (e.g. windows and glass panes). Always make an environmental impact assessment based on the power and sound pressure data in chapter "3.7.7 Deaerator" and the sound emission limits according to the installation area of the unit, with reference to the DPCM of 14/11/1997. An assessment must also be made if the unit is installed near workers, according to D. LGS. 81/2008 Art. 189 and following or according to the installation area of the unit. To reduce vibrations and noise, the use of rubber seals is recommended for wall installation.

	<b>Suspended installation is prohibited.</b>
	<b>The support plane must have enough capacity to support the unit weight, which can be checked both on the technical label of the unit and on this technical manual under "Technical data" chapter. The support plane must not be inclined to ensure the unit works properly and avoid a possible overturning. The support plane must not be smooth, to avoid water/ice deposit as potential sources of danger.</b>

	Unit installation place must be free from foliage, dust, etc., which could clog or cover the coil. Installation in areas subject to water stagnation or fall, for example from gutters, should be avoided. Also, avoid areas subject to snow accumulation (such as corners of buildings with sloping roofs). In case of installation in areas subject to snowfall, it is advisable to place the unit on a base raised from the ground by 20-30 cm, to prevent the formation of snow accumulations around the machine, which can obstruct the battery and the perforations on the side panels and base of the machine.
	It is recommended that sufficient air exchange be ensured to dilute R290 gas in the event of its accidental escape, thus preventing the formation of explosive atmospheres. For this reason, a minimum distance (depending on the unit) must be maintained from any openings or manholes, in which the gas could accumulate. Respect national regulations for the installation of the machine.
	The units are suitable for installation in urban, industrial, coastal and rural areas. If the unit is installed in an environment with aggressive atmospheres, the air sucked in by the fan may contain substances that can cause damage to the panels, grilles and internal components of the unit. In this case, the operating life of the unit will be limited.
	It is forbidden to install the unit under roofs of any kind, such as roofs, canopies, carports and the like, at a height of less than 1.5 m from the unit cover.
	It is prohibited to install the unit in a location below ground level (such as cellars, underground car parks, basement or underground work rooms, etc.).

It is very important to avoid recirculation between intake and delivery air, so as not to downgrade performance of the unit or even to interrupt its normal operation. This is why the minimum clearances shown below must be strictly guaranteed.

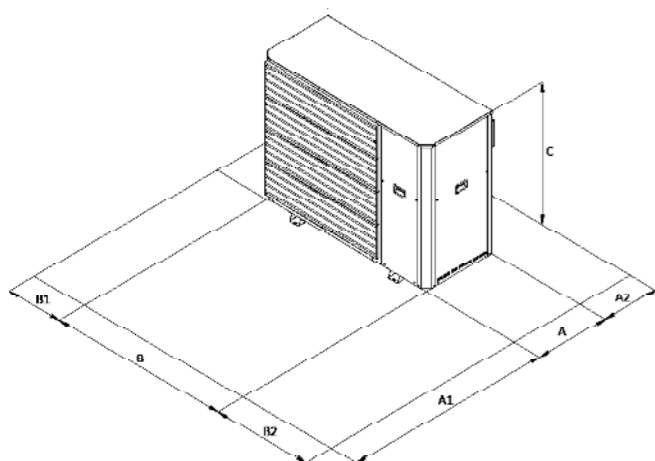

MODEL		A1	A2	B1	B2
SHP290 21 kW	mm	1500	400	400	500
SHP290 23 kW	mm	1500	400	400	500
SHP290 25 kW	mm	1500	400	400	500
SHP290 27 kW	mm	1500	400	400	500

	Obstruction or covering of ventilation openings on the top cover must be avoided.
	For strong wind installation place refer to the classification of the area according to the Beaufort table. If the value is > 7 (strong wind, average wind speed = 13, 9-17, 1 m/s) it is strictly necessary to keep the fan always powered, thus preventing involuntary rotation of the same.
	If the unit is installed at a distance of less than 1 km from coastal and maritime areas, the presence of salt and sand in the air greatly increases the likelihood of corrosion. Install the unit so that it is protected from direct sea wind if necessary, provide windbreaks on site (observing the minimum distances indicated).

In the event of side-by-side units, the minimum $L_{min}$ distance between them is 1 m.	
Covering with canopies or placing near plants or walls should be avoided to prevent air recirculation.	
In the event of winds stronger than 13,9-17,1 m/s (strong wind according to the Beaufort scale) the use of the wind barriers is recommended.	

### 3.6 DANGER AND SAFETY ZONES

The SHP290 series units contain R290 refrigerant gas. The density of this gas is greater than that of air, so in the event of leakage it tends to disperse and stratify, accumulating in niches, depressions in the ground or underground regions. It is mandatory to comply with the danger and safety zones given in this manual, when installing the units. These zones have been designed in accordance with EN 60079-10-1, estimating an appropriate refrigerant loss, in order to guarantee the safety of the units in the installation area. A **danger zone** is defined as a area around the machine in which, in the event of a leakage of refrigerant gas, a flammable atmosphere is formed for a short time, within which it is necessary to implement all the precautions described in the manual. In the absence of specific standards or regulations, when using the unit in an industrial or working environment, it is advisable to carry out the classification of places with explosion hazards considering the ATEX Directive 1999/92 (Directive 89/391). There must NOT be any sources of ignition in the danger zones, including:

- Flammable gases and sprays, self-igniting powders;
- Electrical equipment that is not suitable for use in potentially explosive areas (zone 2 according to Directive 89/391);
- Naked flames, heated surfaces (maximum surface temperature of 360°C) and processing by heat; smoking is prohibited, including for electronic cigarettes;
- Sparks, electrostatic charges, direct and indirect lightning effects, eddy currents and cathodic protection;
- Ignition sources due to remote processes (ionising and non-ionising radiation);
- Permanent electrical sources (switches, lamps, etc.) or other possible triggers;

In addition, danger zone must NOT:

- Include potentially dangerous areas or elements such as wells, manholes, openings to the sewage system and other openings to underground places and premises (e.g. garages), river drains, power lines, flammable deposits, electrical installations, etc.;
- Include doors, windows or glass panes, to prevent the possible return of the gas inside the building;
- Extending towards neighbouring residential properties, parking areas, public access sites, roads or railways.

A **safety zone** extending beyond the danger zone must also be identified. Within the safety zone, in the event of a refrigerant leak, the concentration of the gas in the air is typically below the critical levels for the formation of flammable or hazardous atmospheres. Compliance with the following provisions remains mandatory:

- Prevent accumulation and stagnation in underground spaces, drains, manholes, cellars, etc.;
- Do not place building vents inside or near the safety zone;
- Do not use naked flames and other direct heat sources.

In any case, comply with national and local regulations for the installation of machinery (where applicable) in order to prevent the formation of fire hazards and to prevent gases from seeping underground into openings to the ground or floors below.

No structural modifications may be made in the danger and safety zones that would alter their extent or change the behaviour of the air-coolant mixture.

It is also strictly forbidden to tamper with, alter, remove or compromise, even partially, the functionality of the devices, guards and prescriptions provided for the safety of property and persons.

In this manual, different types of outdoor installation are considered, as indicated in the following paragraphs.

### 3.6.1 Free-field ground installation

For unit installed in open field terrain, the danger (continuous red line) and safety zones (dashed black line) are shown in the figures below:

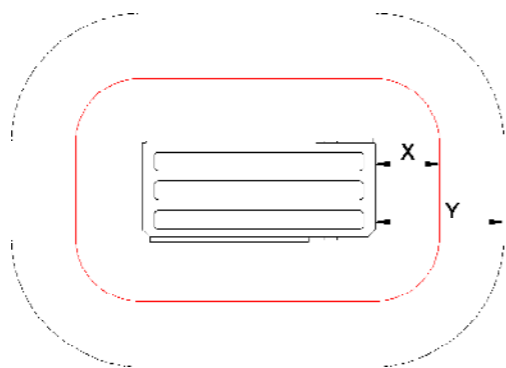
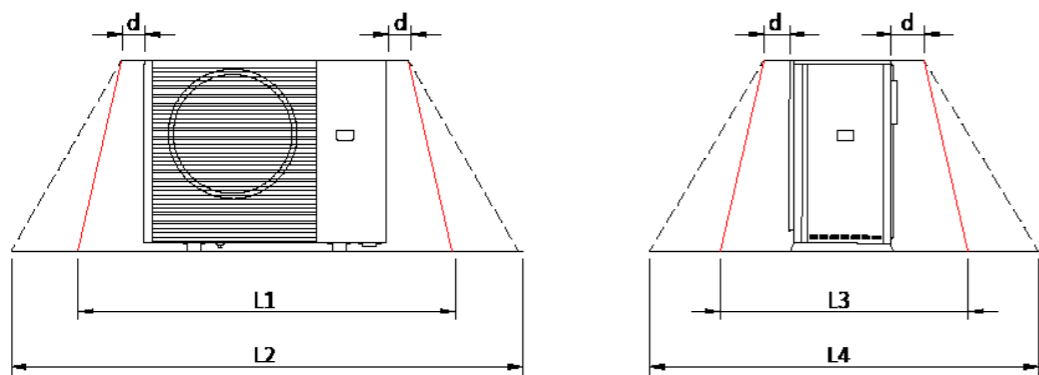

MODEL SHP290		X	Y	L1	L2	L3	L4	d
21 kW / 23 kW	mm	1500	2000	4600	5600	3640	4640	250
25 kW / 27 kW	mm	1500	2000	4600	5600	3640	4640	250

### 3.6.2 Ground installation in front of a wall

In the case of units installed on the ground in front of a wall, the danger (continuous red line) and safety zones (dashed black line) are shown in the figures below:

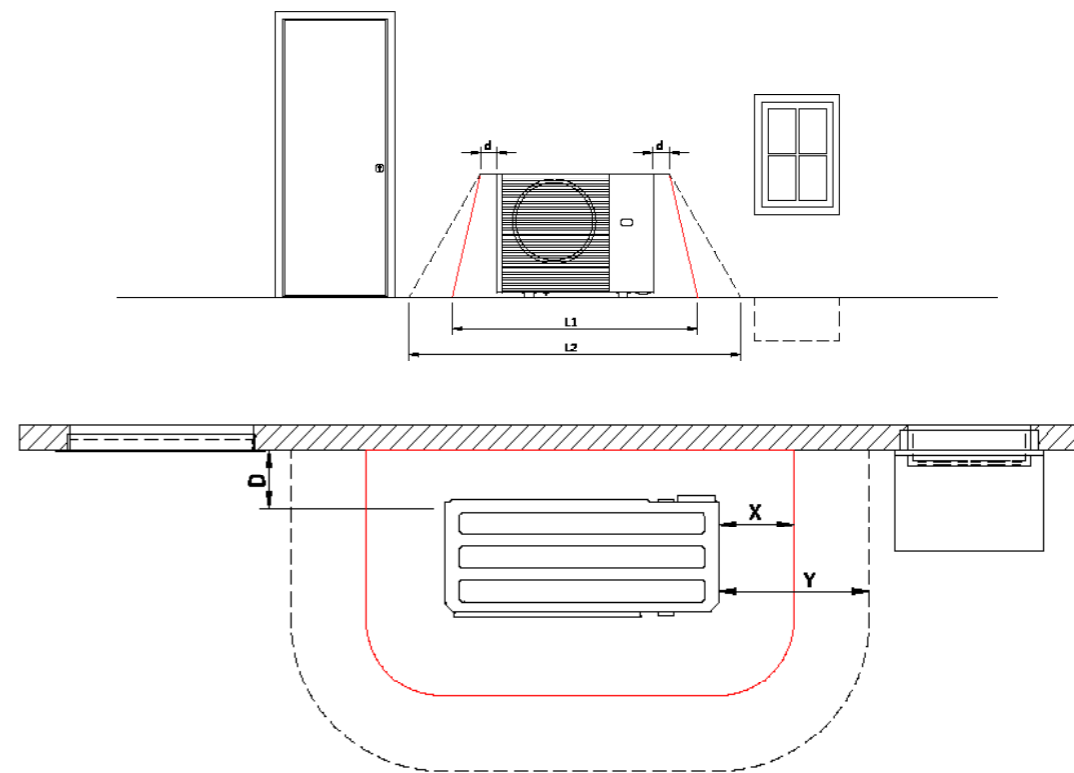

MODEL SHP290		X	Y	L1	L2	D	d
21 kW / 23 kW	mm	1500	2000	4600	5600	400	250
25 kW / 27 kW	mm	1500	2000	4600	5600	400	250

### 3.6.3 Ground installation in a corner

For units installed on ground in a corner, the danger (continuous red line) and safety zones (dashed black line) are shown in the figures below:

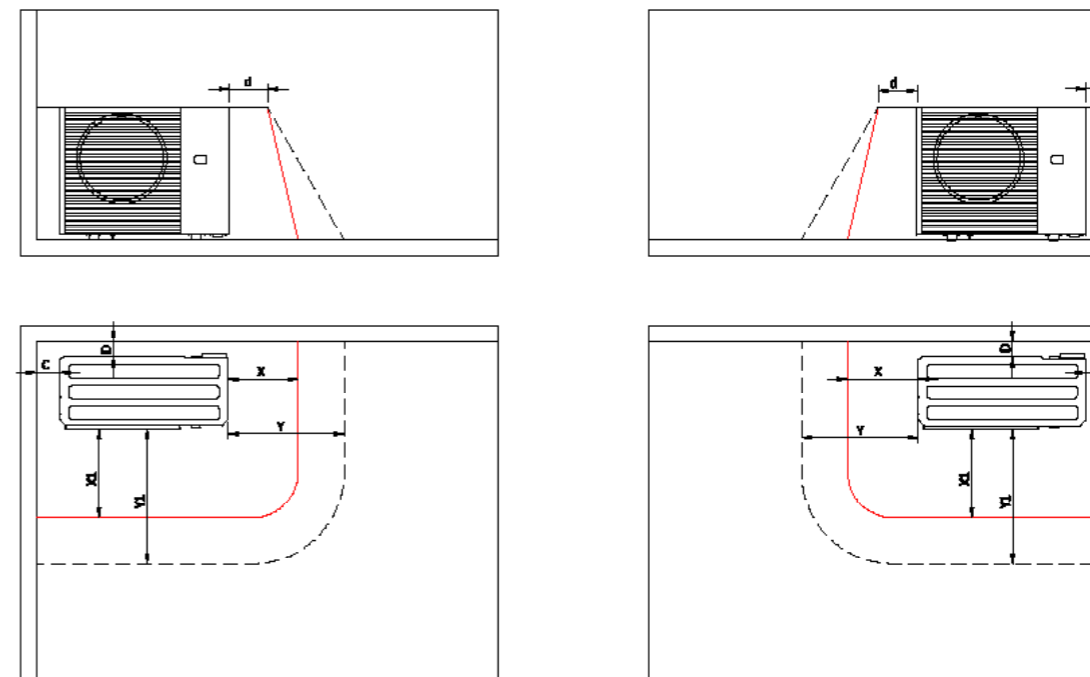

MODEL SHP290		X	Y	X1	Y1	B	C	D	d
21 kW	mm	1500	2000	2750	3250	700	400	400	250
23 kW	mm	1500	2000	2750	3250	700	400	400	250
25 kW	mm	1500	2000	2750	3250	700	400	400	250
27 kW	mm	1500	2000	2750	3250	700	400	400	250

### 3.6.4 Flat floor installation

The installation configuration on a flat roof is similar to that on a free-field ground, although some additional aspects must be considered:

- place the machine at a sufficient distance from side walls and protrusions, which must therefore be beyond the safety zone;
- ensure that the roof structure of the building is solid;
- choose a location where no accumulations of snow, dust or foliage can form;
- pay attention to noise emissions and maintain an adequate distance from surrounding buildings;
- if high air velocities are detected, install the protections listed in the previous chapter.

### 3.6.5 Multiple installation

When installing several machines side by side, follow the above configurations, maintaining a respect distance of L between each machine. As an example, see the following respect zones (danger and safety) for the case of a generic number "n" of units installed on open field terrain:

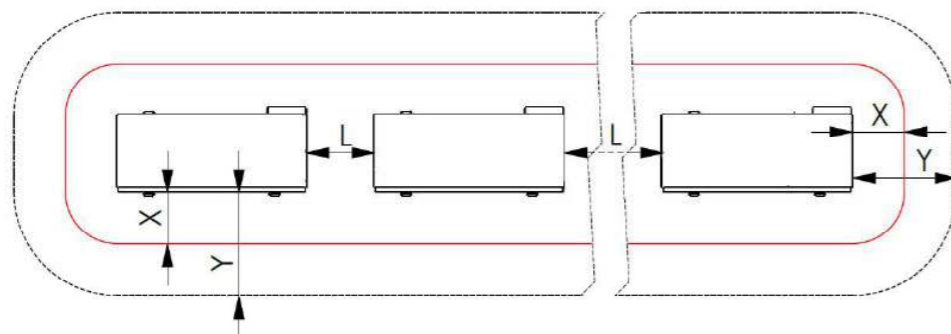

MODEL SHP290		X	Y	L
21 kW	mm	1500	2000	1000
23 kW	mm	1500	2000	1000
25 kW	mm	1500	2000	1000
27 kW	mm	1500	2000	1000

For other types of installation not covered in this manual, contact technical support. If in doubt about the installation of the units, request a technical assessment by the fire brigade or a fire prevention expert.

## 3.7 PLUMBING CONNECTIONS

The plumbing connections must be made in accordance with national and/or local regulations; pipes can be made of steel, galvanised steel, multilayer steel or PVC. Pipes must be accurately sized according to the maximum water flow rate of the unit and the pressure drops of the water circuit. All pipes must be insulated with closed-cell material of adequate thickness. The chiller must be connected to the pipes using new flexible joints, not reused ones. The water circuit should include the following components:

- Well thermometers to monitor the circuit's temperature.
- Manual gate valves to isolate the chiller from the water circuit.
- Metal Y filter or a dirt separator (installed on the return pipe) with metal mesh no larger than 1 mm.
- Loading group and exhaust valve where necessary.



**When sizing the pipes, make sure not to exceed the maximum pressure drop on system side reported in the technical data table in Chapter 3.7.7 (see useful head).**

**Connect the pipes to their fittings always using the key-to-key method.**

**Create a suitable drain for the safety valve.**

**CAUTION: The installer has to verify if the expansion tank fits with the real capacity of the installation.**

**CAUTION: The return pipe from the system must be at the "WATER INPUT" label otherwise the evaporator may freeze.**

**CAUTION: It is mandatory to install a metal filter (with mesh no larger than 1 mm) on the return pipe from the system labelled "WATER INLET". Alternatively, it is possible to install a dirt separator that guarantees a filtration degree of no more than 1 mm; in this case is not necessary to install the Y-filter.**  
**If the flowmeter is tampered with or altered, or if the metal filter or the dirt separator are not present on the system, the warranty shall expire. The filter (or the dirt separator) must be kept clean, therefore, after installing the unit, you must make sure that they are still clean and check them regularly.**

**CAUTION: All the units leave the company supplied with flowmeter (installed in factory). If the flowmeter is altered or removed or if the water filter and dirt separator are missing from the unit, the guarantee shall expire. Refer to the wiring diagram attached to the unit to connect the flowmeter. Never jumper connections of the flowmeter in the terminal block.**

**The heating system and the safety valves must comply with the requirements of standard EN 12828.**

### 3.7.1 Characteristics of the circuit water

To guarantee correct operation of the unit, the water must be appropriately filtered (see the instructions at the start of this paragraph) and there must be only a minimum amount of dissolved substances. The maximum allowed values are shown below:

MAXIMUM CHEMICAL-PHYSICAL PROPERTIES ALLOWED FOR THE CIRCUIT WATER	
PH	7,5 - 9
Electrical conductivity	100 - 500 µS/cm
Total hardness	4,5 - 8,5 dH
Temperature	< 78 °C
Oxygen content	< 0,1 ppm
Max glycol quantity (*)	10 %
Phosphates (PO <sub>4</sub> )	< 2 ppm
Manganese (Mn)	< 0,05 ppm
Iron (Fe)	< 0,3 ppm
Alkalinity (HCO <sub>3</sub> )	70 - 300 ppm
Chloride ions (Cl <sup>-</sup> )	< 50 ppm
Sulphate ions (SO <sub>4</sub> )	< 50 ppm
Sulphide ions (S)	No one
Ammonium ions (NH <sub>4</sub> )	No one
Silice (SiO <sub>2</sub> )	< 30 ppm

(\*) It is preferable to use pure water. Do not add more antifreeze than the maximum quantity specified in this manual.

3.7.2 Typical plumbing diagram

Refer to the "Handbook" for further information regarding possible unit installation configurations.

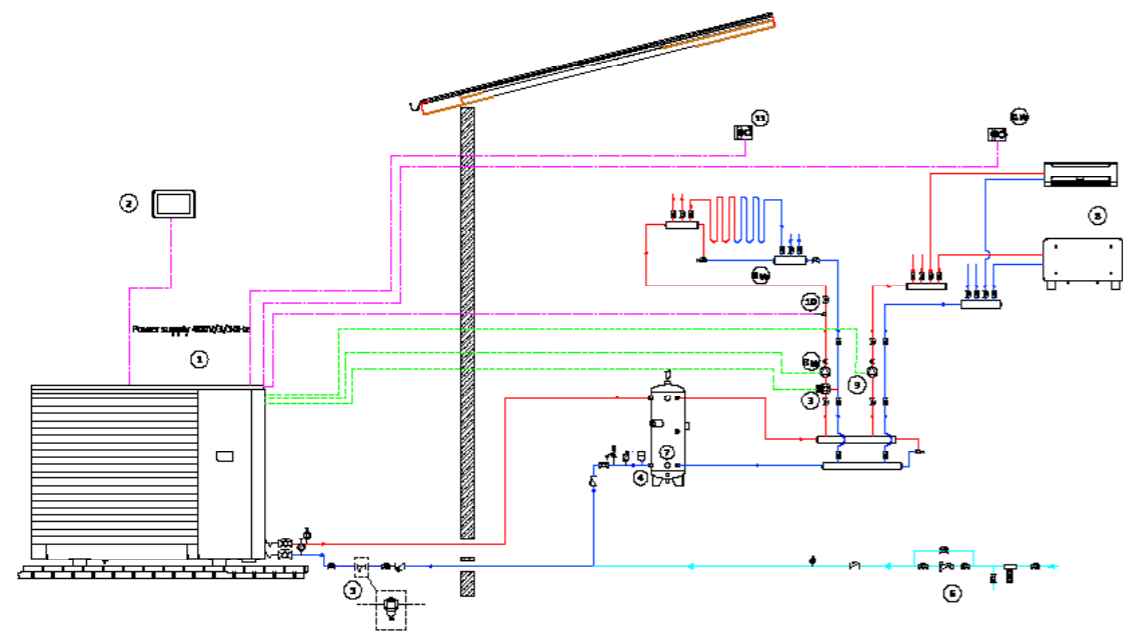

Num.	Description
1	Heat pump
2	Remote control
3	Mixing valve
4	Expansion tank
5	Y-filter or Dirt separator with integrated filter
6	Expansion tank
7	Technical storage
8	Booster pump for zone 1
9	Booster pump for zone 2
10	Mixing probe
11 / 11 bis	Local thermostat

3.7.3 Minimum water content and hydraulic circuit volumes

The table shows the minimum system water content recommended for the unit. The volume of the hydraulic circuit is also indicated. To ensure proper operation of the heat pump, this minimum content must be met. Taking into consideration the volume of water in the primary circuit piping, size the thermal flywheel to achieve the indicated volume.

Model SHP290	21 kW	23 kW	25 kW	27 kW
Minimum system water content [L].	175	175	220	225
Hydraulic circuit volume [L]	3,6	3,6	4,0	4,0

3.7.4 Plumbing diagram inside unit

Since the pipes are well insulated, condensation production is minimal and does not lead to water accumulating inside the refrigeration compartment. All heat pumps have a condensate drain hole in the basement, which is abundant especially in the post-defrost phase.

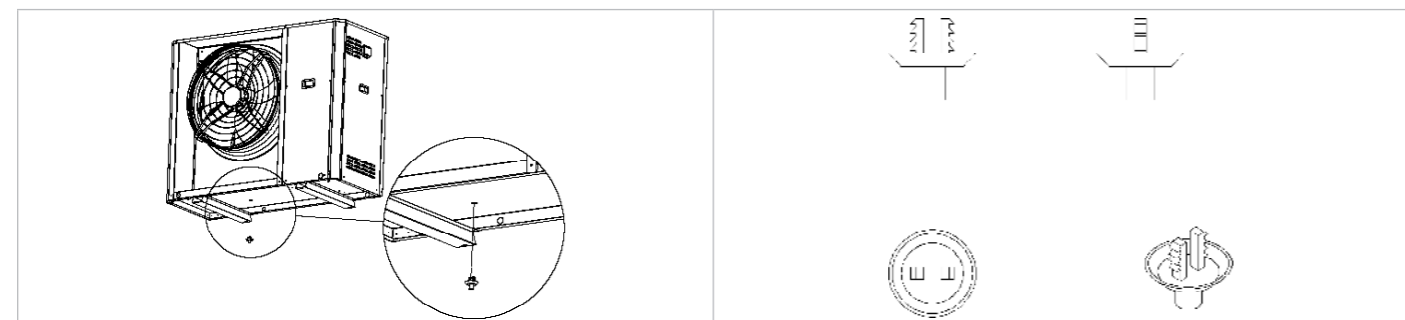

FOR HEAT PUMP UNITS, IN PARTICULARLY COLD CLIMATES, WE RECOMMEND THE INSTALLATION OF THE KA ACCESSORY, WHICH PREVENTS THE FORMATION OF ICE ON THE BASEMENT.



**ATTENTION:** For heat pump units, if the prepared ducting system is not used, a limited amount of water (possible ice in winter) from the condensate drainage system may be deposited in the vicinity of the unit, posing a slip/fall hazard.

Each unit is provided with a hole on the base frame of the hydronic kit (at the side of the coil) for draining any condensate that may percolate from the plumbing pipes and the water that forms as a result of the defrosting process. In the event of a leak, the refrigerant gas may escape from the unit through the hole in the base panel, so it is advisable to always direct the condensate drain to an open place near the unit (within the danger zone defined in Chapter 3.6). If the unit is installed on the ground, it is also possible to direct the condensate into a bed of rubble or gravel for drainage. For typical free-field ground installation, refer to the following pictures:

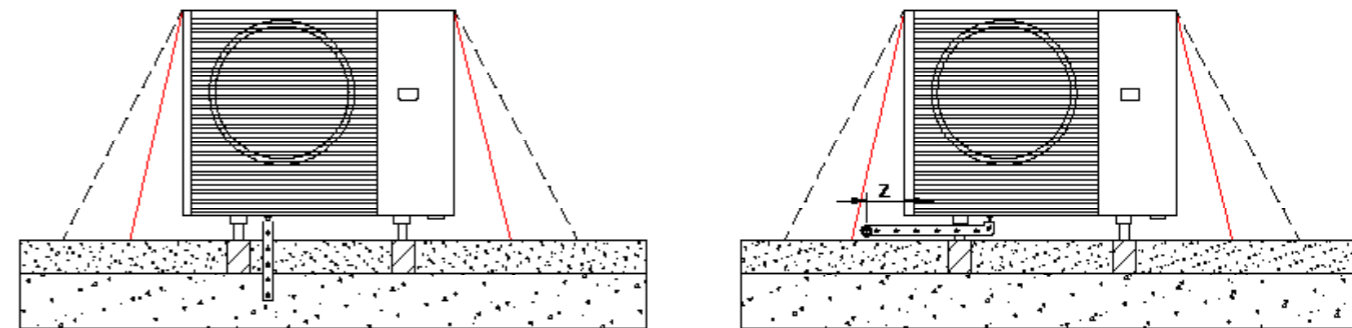

MODEL		Z
SHP290 21 kW	mm	< 250
SHP290 23 kW	mm	< 250
SHP290 25 kW	mm	< 250
SHP 290 27 kW	mm	< 250

**Caution:** Do not obstruct the hole in the base panel for condensate drainage.

Especially in very cold climate regions, it is recommended to install elevation supports in order to allow ice formation under the unit without damaging it by freezing.

### 3.7.5 System load

	<b>CAUTION:</b> Supervise all filling/reintegration operations.
	<b>CAUTION:</b> Before filling/reintegration the system, disconnect power to the units.
	<b>CAUTION:</b> The filling / reintegrating of the system must always take place under controlled pressure (max. 1). Ensure that a pressure reducer and safety valve is installed on the filling/reintegration line.
	<b>CAUTION:</b> The water in the filling/reintegration line must be properly pre-filtered from impurities and suspended particles. Ensure that a removable cartridge filter and a dirt separator are installed.
	<b>CAUTION:</b> Regularly check and vent the air built up in the system.
	<b>CAUTION:</b> Install an automatic air venting valve at the highest point of the system.

### 3.7.6 System discharge

If the unit needs to be drained completely, first close the manual inlet and outlet gate valves (not included in supply) and then detach the pipes on the outside of the water inlet and outlet to drain liquid from the unit (to make this operation easier, it is recommended to install two drain valves between the unit and manual gate valves on the outside of the water inlet and outlet).

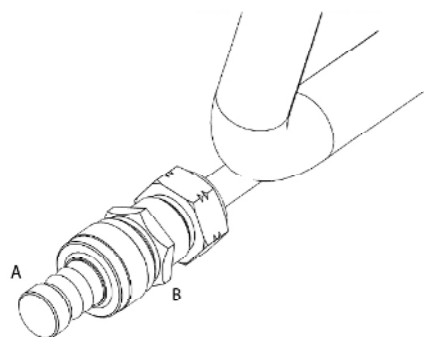

If it is necessary to top up the system or adjust the glycol content, the service tap can be used. Unscrew the cap of the service tap (A) and connect a pipe of 14 or 12 mm (inertial diameter measurements - check the tap model installed on your unit) connected to the water mains to the hose connector, then fill the system by unscrewing the ring nut (B). Once the operation is completed, tighten the ring nut (B) again and screw the cap (A). In any case, it is advisable to use an external tap to fill the system.

### 3.7.7 Deaerator

The unit is equipped with a high-efficiency deaerator that continuously captures and eliminates air and any refrigerant gas that may accumulate within the hydraulic circuit, avoiding undesirable effects such as premature corrosion and wear, reduced efficiency and exchange yield, as well as possible contamination of the water by R290 gas. The exhaust capacity is very high, with automatic gas expulsion down to micro-bubble level.

The deaerator is made of brass, a strong and durable material.

The mixture of water and glycol can greatly reduce the deaerator's ability to remove dissolved gases: it is recommended to limit the glycol concentration to a maximum of 10%. Use products with a low tendency to foam, which could completely nullify the degassing effect and damage the system.



**Do not exceed the maximum amount of glycol indicated in the manual, as this may reduce the deaerator's ability to remove gas, causing damage to the component.**

	<b>Access to the moving parts that control the vent is obtained, after tapping the system, by removing the top cover.</b>	
	<b>After tapping the system, unscrew the part of the body containing the vent valve, to which the separator element is attached, for cleaning. This part is not removable.</b>	

## 4. GENERAL TECHNICAL DATA

Performance referring to the following conditions, according to standard UNI EN 14511:2022:

- (1) Cooling: outdoor air temperature 35 °C; in/out water temperature 12/7°C.
  - (2) Cooling: outdoor air temperature 35 °C; in/out water temperature 23/18°C.
  - (3) Heating: outdoor air temperature 7 °C db 6 °C db; in/out water temp. 30/35°C.
  - (4) Heating: outdoor air temperature 7 °C db 6 °C db; in/out water temp. 47/55 °C.
  - (5) Cooling: low temperature,variable output, fixed flow rate.
  - (6) Heating: average climatic conditions; T<sub>biy</sub> = -7 °C; low temperature,variable output, fixed flow rate.
  - (7) Indicative data subject to changes. For the correct value, always refer to the technical label on the unit.
  - (8) Calculated for a decrease in system water temperature of 10°C with a defrost cycle lasting 6 minutes.
  - (9) Sound mode: mode (1); value determined on the basis of measurements made in accordance with UNI EN ISO 9614-1.
  - (10) Sound pressure: value calculated from the sound power level in condition (9) using the standard UNI EN ISO 3744:2010.
  - (11) Sound mode: heating mode according to EN 12102:2022 Annex A; value determined on the basis of measurements made in accordance with UNI EN ISO 9614-1, in compliance with Eurovent certification requirements.
  - (12) Heating: outdoor air temperature 7 °C db. 6 °C db; in/out water temp. 55/65 °C.
- <sup>(\*)</sup> activating the maximum Hz function.

**N.B. performance data are indicative and are subject to change. Furthermore the performance declared in points (1), (2), (3) and (4) is intended to refer to instantaneous power according to EN 14511:2022. The value declared in point (5) and (6) is determined according to UNI EN 14825:2022.**

TECHNICAL CHARACTERISTICS		Unit	SHP290			
			21 kW	23 kW	25 kW	27 kW
Cooling	Cooling capacity (1)	kW	17,4	18,9	19,8	22,3
	Power input (1)	kW	5,26	5,9	6,2	7,2
	EER (1)	W/W	3,31	3,21	3,20	3,10
	Cooling capacity (2)	kW	19,6	21,0	25,3	27,9
	Power input (2)	kW	4,02	4,4	5,3	6,4
Heating	EER (2)	W/W	4,88	4,79	4,76	4,34
	SEER (5)	W/W	5,27	5,27	4,94	4,84
	Water flow (1)	L/s	0,83	0,90	0,95	1,07
	Heating capacity (3)	kW	21,0	22,8	24,8	27,0
	Power input (3)	kW	4,3	4,8	5,4	6,2
	COP (3)	W/W	4,87	4,77	4,62	4,35
	Heating capacity (4)	kW	19,6	21,6	23,2	26,3
	Power input (4)	kW	6,1	6,8	7,7	8,7
	COP (4)	W/W	3,20	3,18	3,03	3,01
	Heating capacity (12)	kW	19,7	21,2	24,1	25,8
	Power input (12)	kW	7,4	8,0	9,6	10,3
	COP (12)	W/W	2,67	2,66	2,52	2,50
	SCOP (6)	W/W	4,75	4,72	4,49	4,46
Water flow (4)	L/s	0,59	0,65	0,69	0,79	
Energy efficiency - water 35°C / 55°C low temperature / medium temperature		Class	A+++ / A++	A+++ / A++	A+++ / A++	A+++ / A++
Compressor	Type	-	Scroll DC Inverter			
	Quantity	-	1	1	1	1
	Refrigerant oil (type)	-	PZ46M	PZ46M	PZ46M	PZ46M
	Refrigerant oil (quantity)	mL	900	900	900	900
Refrigerant	Refrigerant circuits	-	1			
	Type	-	R290			
	Refrigerant quantity (7)	kg	1,7	1,7	2,1	2,1
	Refrigerant quantity in tonnes of CO2 equivalent (7)	ton	0,000034	0,000034	0,000042	0,000042
	Design pressure (high/low) heat pump mode	bar	30,3 / 1,7			
Fans	Design pressure (high/low) chiller mode	bar	30,3 / 0,7			
	Type	-	EC			
	Quantity	-	1			
	Nominal power (1)	kW	0,40	0,43	0,6	0,6
	Maximum power input	kW	0,83	0,83	0,8	0,8
Internal heat exchanger	Maximum current input	A	1,2	1,2	1,2	1,2
	Nominal air flow	m³/h	12520	12810	13770	13780
	Internal heat exchanger type	-	A piastre / BPHE			
	N° internal heat exchanger	-	1	1	1	1
Hydronic circuit	Water content	L	1,71	1,71	2,07	2,07
	Useful head (1)	kPa	128	121	128	117
	Useful head (4)	kPa	150	146	149	142
	Water content of the hydronic circuit	L	4	4	4	4
	Maximum pressure hydronic kit (safety valve setting)	bar	6	6	6	6
	Water connections	inch	1" 1/4 M	1" 1/4 M	1" 1/4 M	1" 1/4 M
	Minimum water volume (8)	L	175	175	220	225
	Nominal pump power (1)	kW	0,35	0,35	0,35	0,35
Noise	Maximum pump power input	kW	0,35	0,35	0,35	0,35
	Maximum pump current input	A	2,50	2,50	2,50	2,50
	Sound power level Lw (9)	dB(A)	72	73	75	76
Electrical data	Sound pressure Lp1 (10)	dB(A)	41	42	44	45
	Sound power level Lw (11)	dB(A)	64	64	65	65
	Power supply	-	400V/3P+N+T/50Hz			
	Maximum power input	kW	11	11	13	13
	Maximum current input	A	19	19	21	21
Electrical data	Max. power input with antifreeze kit	kW	11	11	13	13
	Max. current input with antifreeze kit	A	19	19	22	22

4.1 ELECTRICAL AND AUXILIARY DATA

Power supply	V~/Hz	400/3PH+PE/50
On board controller circuit	V~/Hz	12/1/50
Remote controller circuit	V~/Hz	12/1/50
Fans power supply	V~/Hz	400/3PH+PE/50

NOTE: The electrical data are subject to change due to updates. It is therefore always necessary to refer to the technical specifications label applied on the right side panel of the unit.

5. CORRECTION FACTORS

5.1 CORRECTION FACTORS FOR USE OF GLYCOL WATER MIXTURE

The correction factors of the water flow rate and pressure drops must be applied to the values obtained without use of glycol. The correction factor for the water flow rate is calculated to maintain the same temperature difference which would be achieved without the use of glycol.

Glycol percentage	Freezing point [°C]	Performance correction factor	Absorbed power correction factor	Water flow rate correction factor	Pressure drops correction factor
10%	-3,2	0,992	1,01	1,03	1,11

**Do not add more glycol than the maximum quantity indicated in this manual, as this may severely restrict the deaerator's ability to remove gases, possibly resulting in damage to the component.**

5.2 SCALING CORRECTION FACTORS

The correction factors due to fouling of the internal gas/water heat exchanger are reported below.

m² °C/kW	Output power correction factor	Input power correction factor
0,44 x 10 <sup>-3</sup>	1,00	1,00
0,88 x 10 <sup>-3</sup>	0,99	1,00
1,76 x 10 <sup>-3</sup>	0,98	1,00

5.3 INSTRUMENTATION CALIBRATIONS AND PROTECTIONS

Description	Value
High pressure switch	31,5 bar
High pressure alarm	30,3 bar
Low pressure alarm	0,7 / 1,7
Maximum number of restarts/hour after high/low	3
Antifreeze protection	Allarm triggered: 3 °C Allarm return: 5 °C
Hydronic circuit safety valve	6 bar

5.4 CORRECTION FACTORS ACCORDING TO ALTITUDE

The performance correction factors according to altitude are calculated for cooling at conditions (1) and for heating at conditions (3) of the previous technical data tables and are provided for altitudes of 500, 1000, 1500 and 2000 m.

Altitude [m]	SHP290			
	500	1000	1500	2000
<b>Thermal output correction factor</b>	0,9992	0,9979	0,9970	0,9958
<b>Power input correction factor in heating</b>	0,9985	0,9962	0,9939	0,9916
<b>Cooling output correction factor</b>	0,9961	0,9873	0,9796	0,9746
<b>Power input correction factor in cooling</b>	1,0021	1,0103	1,0149	1,0205

6. HYDRONIC UNIT DATA

6.1 USEFUL HEADS

The following are the characteristic curves of the head-flow rate net of the pressure drops of the hydronic kit. The optimal operating point at the apex (1) and (3) in the technical data table is highlighted on each curve. The system must be designed to guarantee the nominal flow rate relative to the working points shown below.

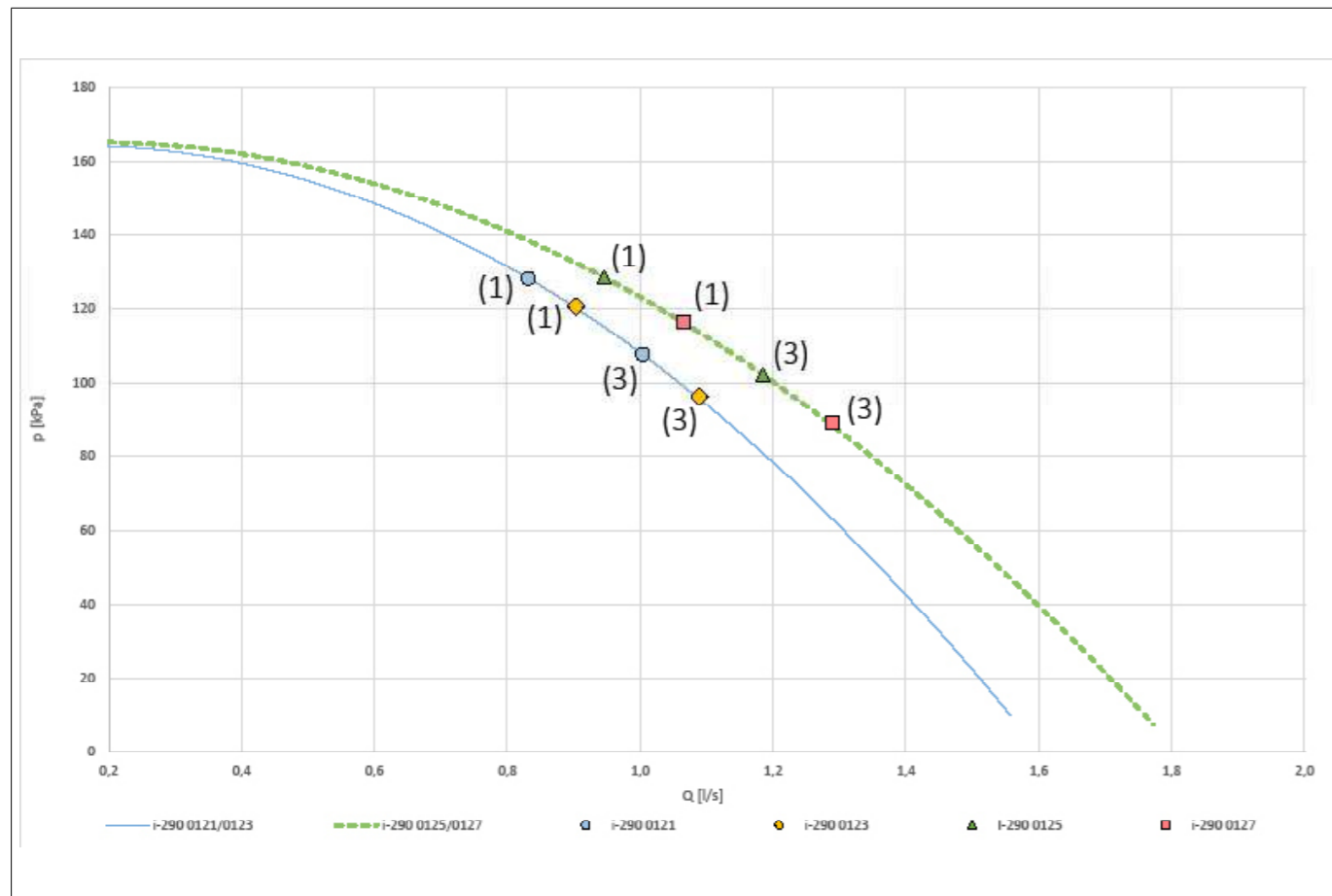

p [kPa]	Useful head
Q [l/s]	Water flow rate

6.2 CIRCULATOR CURVES

Below is the range of useful heads which guarantee the unit during modulating of the circulator.

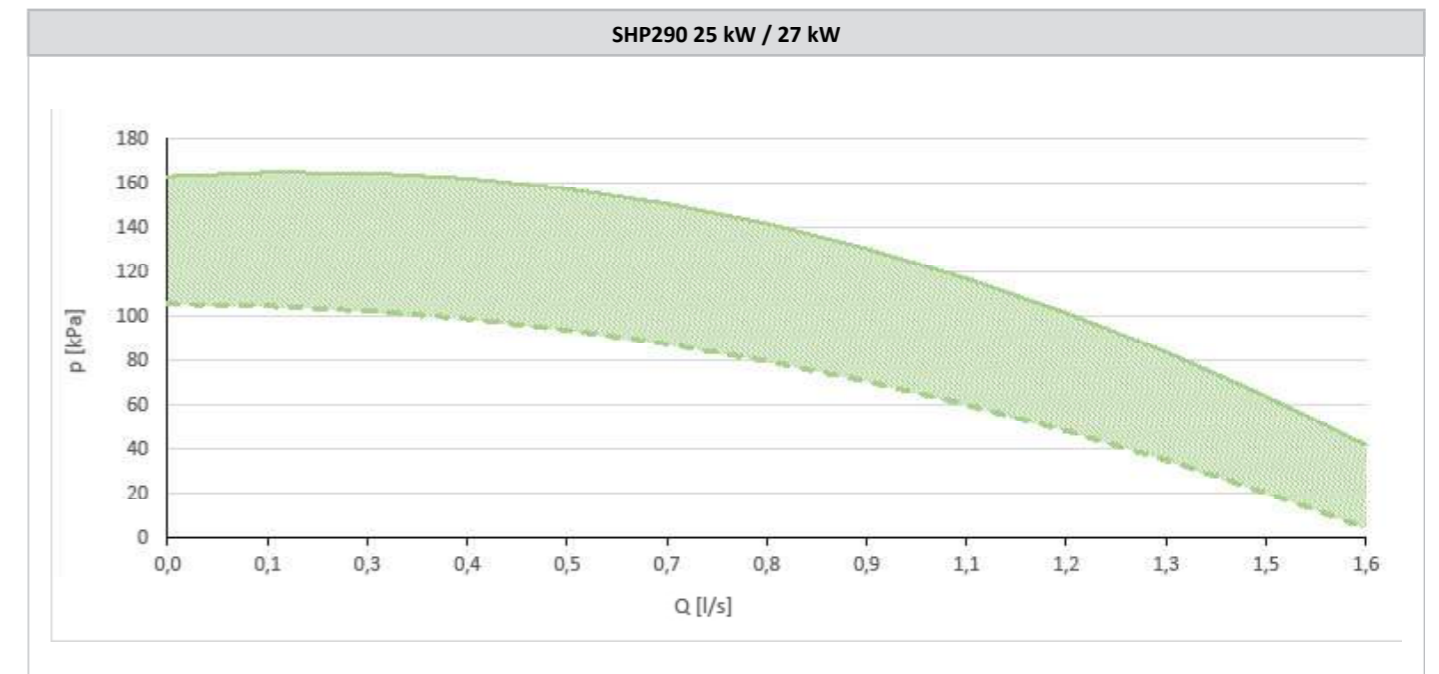
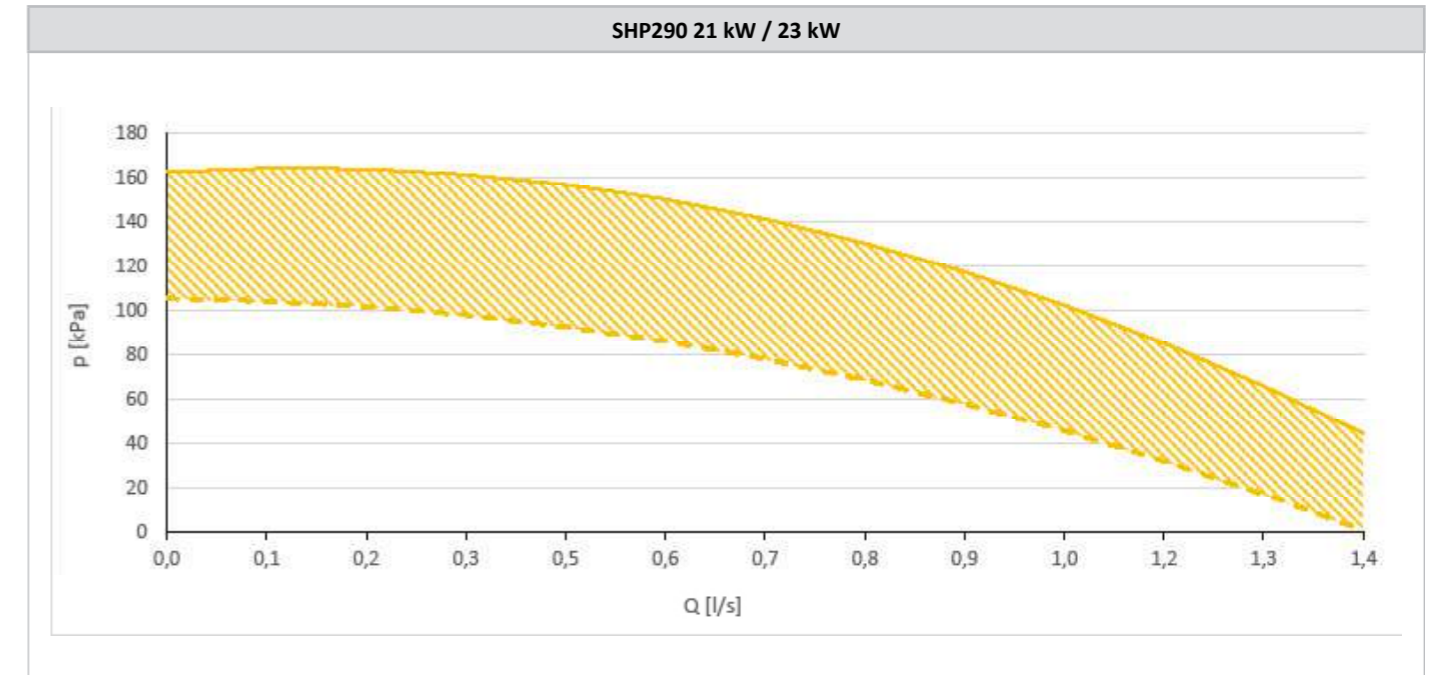

6.3 ACCESSORY PRESSURE DROPS Y-FILTER, DIRT DEFLECTOR AND 3-WAY VALVE

Flow rate [l/s]	Y-filter pressure drops for 21 kW and 23 kW [kPa]
0,4	1,23
0,6	2,76
0,8	4,91
1,0	7,67
1,2	11,0
1,4	15,0
1,6	19,6
1,8	24,8
2,0	30,7

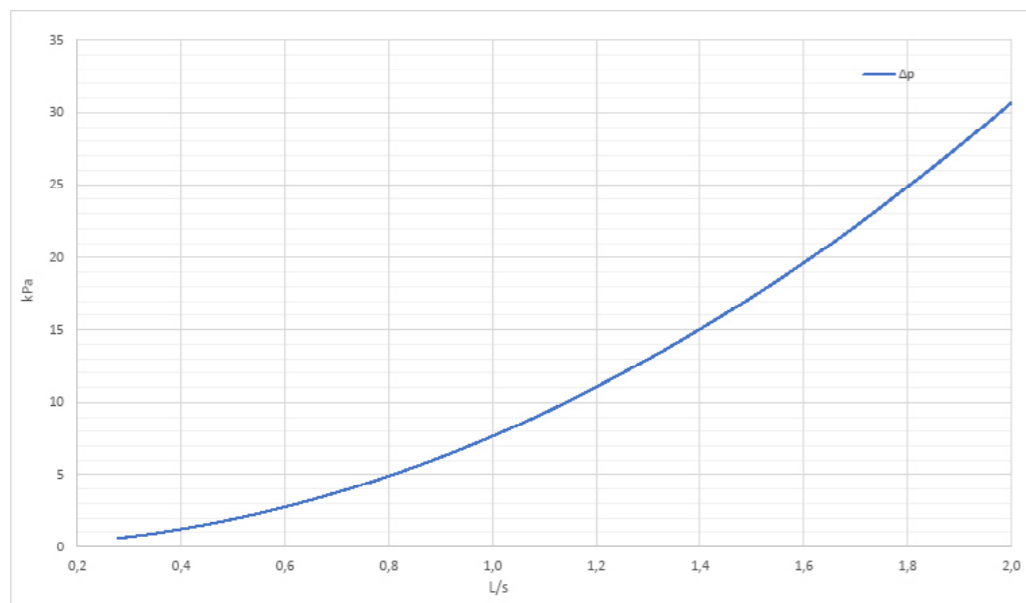

Flow rate [l/s]	Y-filter pressure drops for Y 25 kW for 27 kW [kPa]
0,4	0,92
0,6	2,07
0,8	3,69
1,0	5,76
1,2	8,29
1,4	11,3
1,6	14,7
1,8	18,7
2,0	23,0

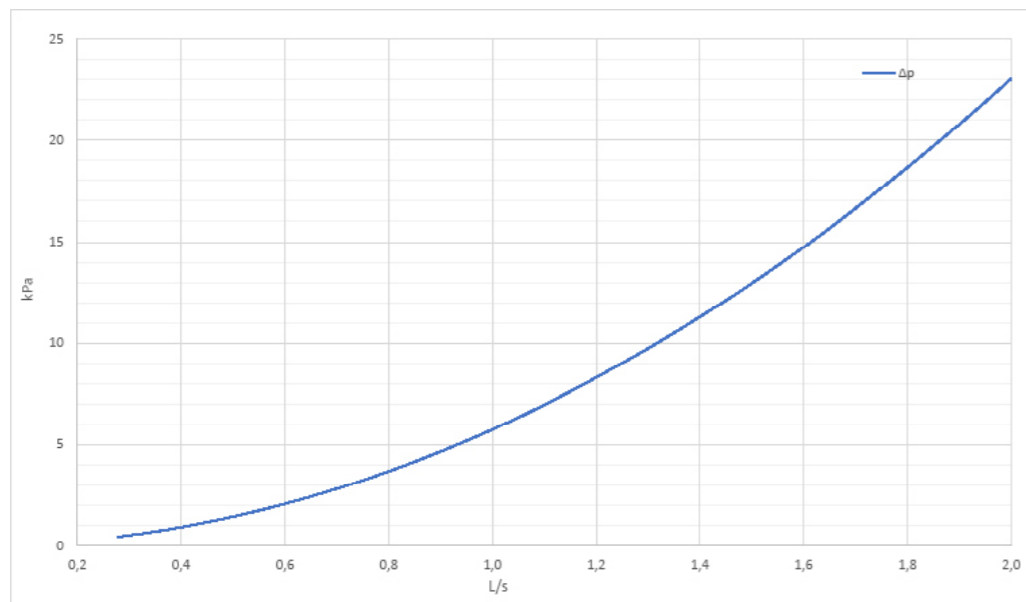

Flow rate [l/s]	Pressures losses dirt separator filter [kPa]
0,4	0,09
0,6	0,19
0,8	0,35
1,0	0,54
1,2	0,78
1,4	1,06
1,6	1,38
1,8	1,75

Flow rate [l/s]	Pressures losses dirt separator filter [kPa]
2,0	2,16

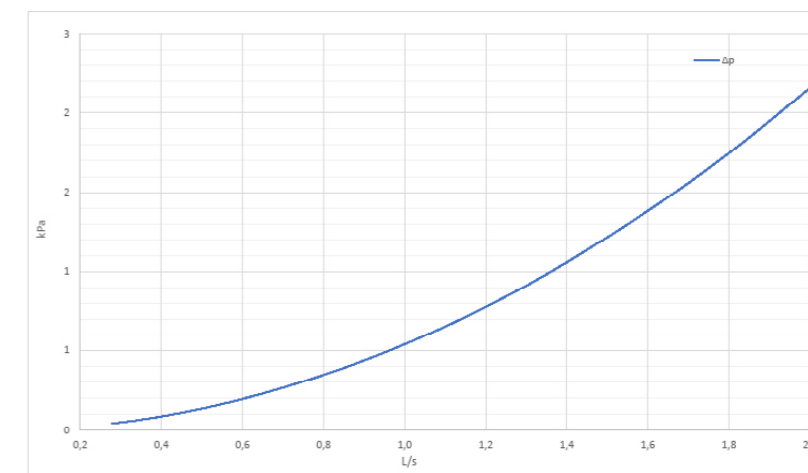

Flow rate [l/s]	Diverter valve pressure loss [kPa]
0,4	0,48
0,6	1,08
0,8	1,92
1,0	3,00
1,2	4,31
1,4	5,87
1,6	7,67
1,8	9,71
2,0	12,0

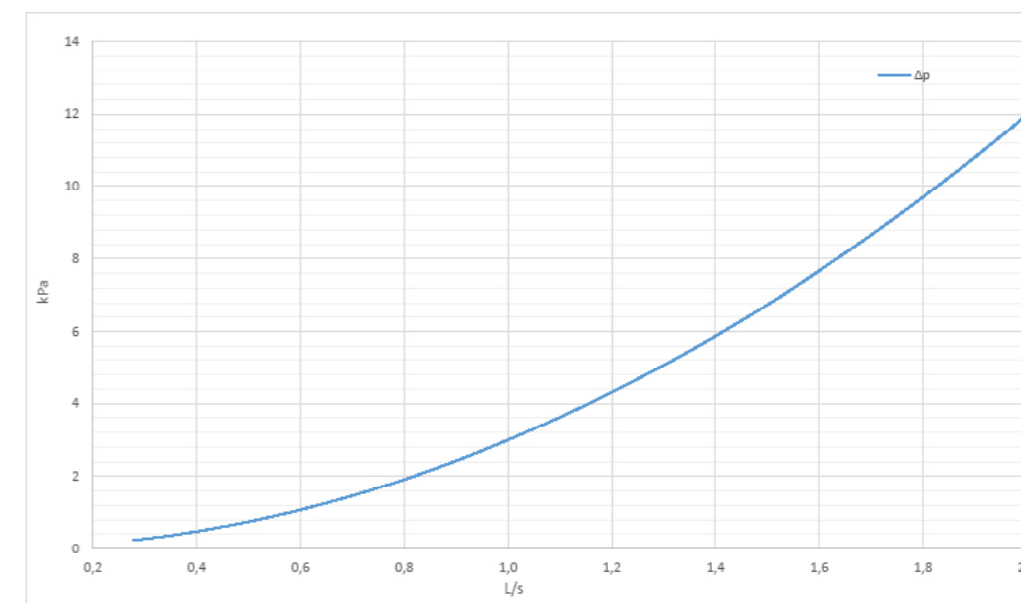

## 7. SOUND EMISSIONS

### 7.1 FULL LOAD UNITS

The sound levels refer to the unit operating at full load and under normal test conditions in cooling mode (outdoor air b.s. (b.u.) temperature = 35 °C (24 °C), inlet-outlet water temperature = 12-7 °C). The tolerance on the total sound power level value is 2 dB(A). The value is determined in accordance with EN 12102-1:2022, used in conjunction with EN ISO 9614-1:2009, which describes the test methods and techniques for measuring sound power using the intensimetric method. Sound pressure values are calculated from the sound power level using UNI EN ISO 3744:2010, considering units operating in the open field.

Model SHP290	Octave band sound power level [dB(A)]							Sound power level Lw(A) [dB(A)]	Sound pressure level at 1m [dB(A)]	Sound pressure level at 10m [dB(A)]
	63 Hz	125 Hz	250 Hz	500 Hz	1000 Hz	2000 Hz	4000 Hz			
21 kW	59,4	56,9	62,5	65,7	66,6	65,5	59,5	72	56	41
23 kW	59,0	59,2	63,2	66,5	68,1	66,2	60,2	73	57	42
25 kW	59,2	61,8	64,6	69,5	70,1	67,7	61,7	75	59	44
27 kW	58,7	62,1	64,5	70,5	70,8	69,8	62,7	76	60	45

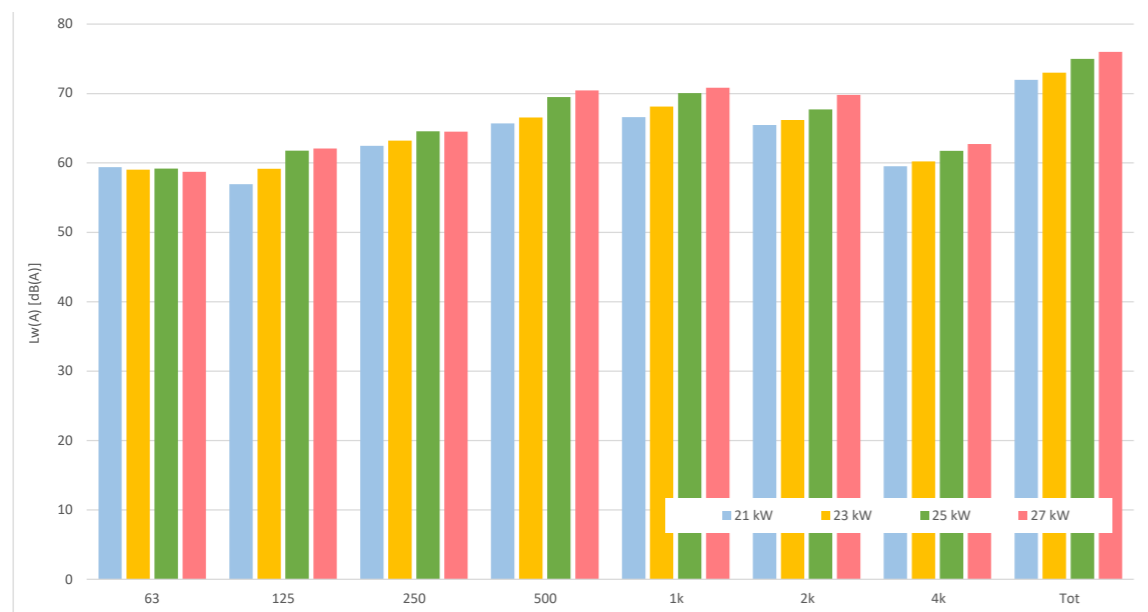

7.2 PARTIAL LOAD UNIT

The sound levels are referred to units at full load operating under conditions that guarantee a thermal capacity equal to that declared at a temperature of 7°C for average climate, in accordance with EN 14825:2022. The tolerance on the value of the total sound power level is 2 dB (A). The value is calculated according with EN 12102-1:2022 regulation used in conjunction with UNI EN ISO 9614-1:2009 which describes the test methods and sound power measurement techniques with the intensimetric method. The sound pressure values are calculated from the sound power level using UNI EN ISO 3744: 2010, considering units operating in the open field.

Model SHP290	Octave band sound power level [dB(A)]							Sound power level Lw (A) [dB(A)]	Suond pressure level at 1m [dB(A)]	Sound pressure level at 10m [dB(A)]
	63 Hz	125 Hz	250 Hz	500 Hz	1000 Hz	2000 Hz	4000 Hz			
21 kW	42,4	50,5	52,3	61,0	56,9	54,6	47,6	64	48	33
23 kW	42,8	51,0	52,8	61,5	57,4	55,1	48,0	64	48	33
25 kW	50,6	50,8	56,3	62,5	54,7	53,0	44,3	65	49	34
27 kW	51,2	51,5	56,9	63,2	55,3	53,6	44,8	65	49	34

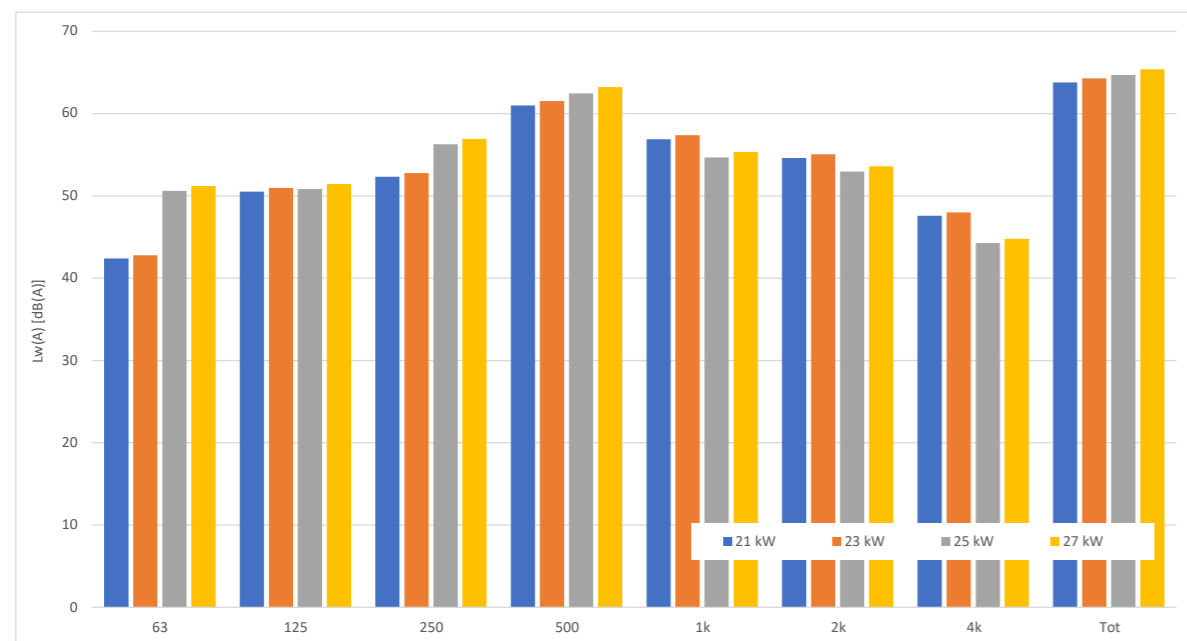

8. OPERATING LIMITS

8.1 EVAPORATOR WATER FLOW

The nominal water flow rate refers to a temperature difference between the inlet and outlet of the evaporator of 5 °C. The maximum permissible flow rate is the one with a temperature difference of 3 °C and the minimum is the one with a temperature difference of 10 °C at nominal conditions as stated in the data sheet.



Insufficient water flow rates can cause excessively low evaporation temperatures causing the safety devices to trigger and stopping the unit and, in some extreme cases, forming ice in the evaporator and resulting in serious failures to the cooling circuit.

For greater details, we have attached a table below with the minimum flow rates for the plate heat exchanger to guarantee proper operation according to the model (please note: the water flowmeter is applied to protect against failed triggering of the antifreeze probe due to the lack of flow but does not guarantee the minimum water flow rate required for correct operation of the unit).

Model SHP290	Chiller mode			
	21 kW	23 kW	25 kW	27 kW
Minimum water flow to be assured in chiller mode (condition (1) technical sheet) [l/s]	0,42	0,45	0,47	0,53
Maximum water flow to be assured in chiller mode (condition (1) technical sheet) [l/s]	1,39	1,51	1,58	1,77
Flowmeter intervention rate – decreasing / increasing flow* [l/s]	0,24	0,25	0,29	0,31



Pay attention to the pressure levels of the hydraulic system: too low values can cause malfunctions of the unit.

For very low hydraulic system pressure values, the flowmeter may show an unstable reading, so it is recommended to have an automatic loading system or a pressure monitoring system.

It is periodically check the state of the deaerator, especially if very high temperature differences are read between the inlet and outlet on the water side, as the presence of air bubbles in the circuit reduces the available water flow rate, altering the flowmeter reading.

As an approximation, and without any other measurement systems, the correct flow rate to guarantee the best performance of the unit can be verified with the circulator at maximum speed, by looking at the pressure gauges to check the pressure difference between the return and discharge water on the external plumbing fittings of the unit and making sure that this reading is equal to or lower than the useful head indicated on the curves shown in Paragraph 6.2 for the respective models.

8.2 COLD WATER PRODUCTION (SUMMER MODE)

A minimum temperature of 5°C is allowed at the evaporator outlet: for lower temperatures, contact the Technical Department. In this case, contact our technical department for a feasibility study and evaluation of the modifications to be made according to the requirements. A maximum temperature of 20°C can be maintained at the evaporator outlet in steady-state operation. Slightly higher temperatures can however be tolerated during transients and in the phases of operation.

8.3 HOT WATER PRODUCTION (WINTER MODE)

When the system has reached steady state, the water inlet temperature must not drop below 20°C: lower values, not due to transient phases or reaching steady-state, can cause system failures and could possibly break the compressor. The maximum outlet water temperature must not exceed 78 °C.

Temperatures higher than those indicated, especially in conjunction with low water flow rates, could lead to malfunctioning of the unit, or in the most critical cases safety devices could be triggered.

8.4 AMBIENT AIR TEMPERATURE AND SUMMARY TABLE

The units are designed and built to operate in summer mode, with condensation control, at outdoor air temperatures between 10°C and 46°C. In heat pump mode, the allowed temperature range of the outdoor air goes from -20°C to +45°C depending on the outlet water temperature as shown in the table below.

Water chiller mode		
Air source temperature	Minimum +10 °C	Maximum +46 °C
Outlet water temperature	Minimum +5 °C	Maximum +20 °C
Heat pump mode		
Air source temperature	Minimum -20 °C	Maximum +20 °C
Outlet water temperature	Minimum +20 °C **	Maximum +78 °C **
Heat pump mode for domestic hot watert		
Air source temperature with water at maximum 60°C	Minimum -20 °C	Maximum +45 °C
Air source temperature with water at maximum 65°C	Minimum -14 °C	Maximum +45 °C
Air source temperature with water at maximum 78°C	Minimum 0 °C	Maximum +38 °C

\*\* The minimum and maximum permissible temperatures depend on the outside air temperature. Set the desired value considering the envelope. Below are the graphed operating limits for heating, cooling and domestic hot water production. Please note that operating the unit outside the stated operating limits causes blocking alarms that lead to product shutdown, with possible damage to components and/or safety organs.

**8.5 ENVELOPE IN HEATING AND COOLING**

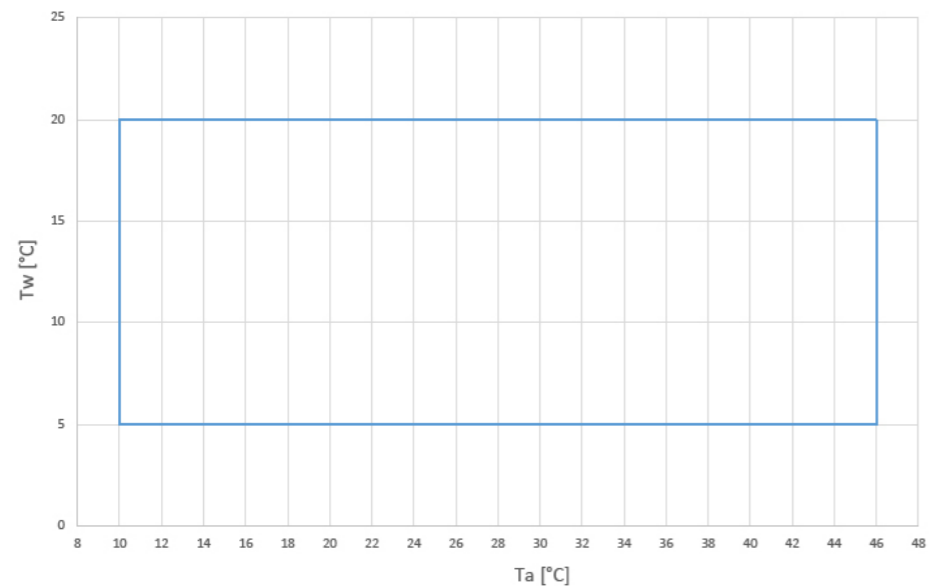
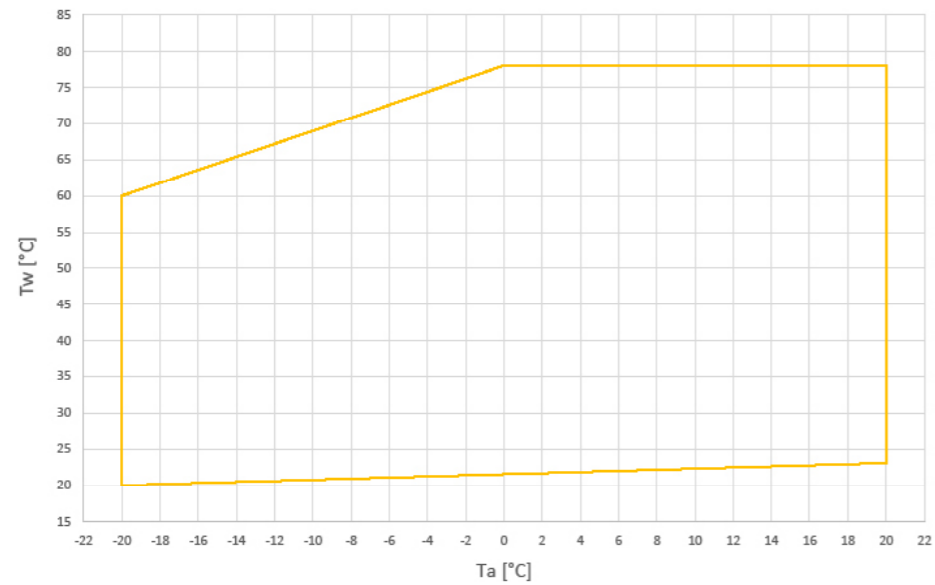

Tw = water temperature  
 Ta = air temperature  
 A = maximum Hz functionality has no effect

**8.6 ENVELOPE IN DHW**

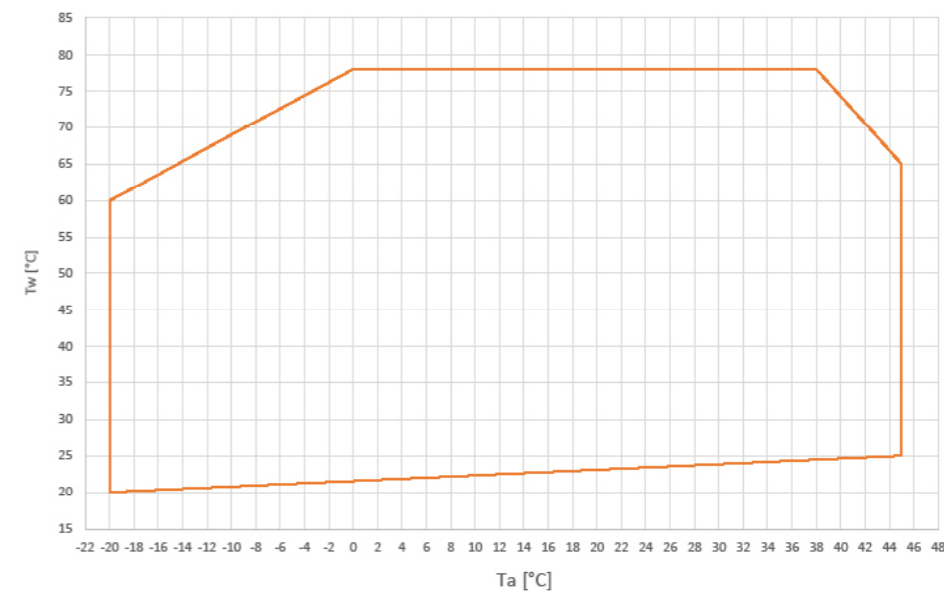

Tw = water temperature  
 Ta = air temperature  
 A = maximum Hz functionality has no effect

9. PERFORMANCE TABLES

The tables show the capacity, power input and efficiency values for different outside air temperatures. The data shown are calculated according to EN 14511:2022. They are indicative and may be subject to change. (\*) Data obtained for a water temperature variation of 5°C unless otherwise specified.

9.1 UNIT HEATING

Model SHP290		HEATING																	
		T air outdoor [°C]	Tout [°C]																
			25			30			35			40			45			50	
Heating capacity [kW]	Power input [kW]	COP [W/W]	Heating capacity [kW]	Power input [kW]	COP [W/W]	Heating capacity [kW]	Power input [kW]	COP [W/W]	Heating capacity [kW]	Power input [kW]	COP [W/W]	Heating capacity [kW]	Power input [kW]	COP [W/W]	Heating capacity [kW]	Power input [kW]	COP [W/W]		
21 kW	-20	14,2	6,09	2,33	13,8	6,45	2,14	13,5	6,82	1,98	13,3	7,19	1,85	13,1	7,62	1,72	12,9	8,06	1,60
	-15	14,6	5,96	2,45	14,2	6,31	2,25	13,9	6,67	2,08	13,7	7,09	1,93	13,4	7,49	1,79	13,2	7,94	1,66
	-10	16,3	5,38	3,03	16,1	5,77	2,79	15,8	6,25	2,53	15,5	6,71	2,31	15,3	7,22	2,12	15,1	7,70	1,96
	-7	18,1	5,11	3,54	17,8	5,51	3,23	17,5	6,05	2,89	17,0	6,54	2,60	16,9	7,10	2,38	16,7	7,66	2,18
	-2	20,2	4,55	4,44	19,7	4,96	3,97	19,2	5,47	3,51	19,0	5,99	3,17	18,8	6,53	2,88	18,4	7,08	2,60
	2	21,6	4,13	5,23	21,2	4,56	4,65	20,3	5,05	4,02	20,2	5,55	3,64	19,9	6,07	3,28	19,6	6,60	2,97
	7	22,3	3,43	6,50	21,5	3,87	5,56	21,0	4,31	4,87	20,7	4,77	4,34	20,4	5,24	3,89	20,1	5,74	3,50
	12	23,1	3,13	7,38	22,3	3,59	6,21	22,0	4,00	5,50	21,6	4,46	4,84	21,2	4,92	4,31	20,7	5,38	3,85
	15	23,3	3,13	7,44	22,8	3,57	6,39	22,2	4,01	5,54	21,7	4,45	4,88	21,3	4,90	4,35	20,8	5,33	3,90
20	24,2	3,20	7,56	23,7	3,64	6,51	23,1	4,08	5,66	22,6	4,50	5,02	22,1	4,92	4,49	21,6	5,35	4,04	
23 kW	-20	14,9	6,65	2,24	14,5	7,04	2,06	14,3	7,41	1,93	14,0	7,82	1,79	13,8	8,26	1,67	13,6	8,72	1,56
	-15	15,5	6,56	2,36	15,1	6,95	2,17	14,8	7,36	2,01	14,5	7,80	1,86	14,3	8,22	1,74	14,0	8,70	1,61
	-10	17,0	6,01	2,83	16,7	6,40	2,61	17,0	6,96	2,44	16,7	7,46	2,24	16,6	8,02	2,07	16,5	8,59	1,92
	-7	18,7	5,72	3,27	18,5	6,13	3,02	18,6	6,71	2,77	18,7	7,31	2,56	18,6	7,91	2,35	18,4	8,56	2,15
	-2	21,2	5,25	4,04	20,8	5,68	3,66	20,8	6,27	3,32	20,9	6,85	3,05	20,7	7,45	2,78	20,6	8,11	2,54
	2	23,7	4,89	4,85	23,1	5,36	4,31	22,8	5,89	3,87	22,6	6,48	3,49	22,4	7,07	3,17	22,2	7,68	2,89
	7	23,9	3,85	6,21	23,3	4,32	5,39	22,8	4,78	4,77	22,5	5,31	4,24	22,2	5,84	3,80	21,8	6,39	3,41
	12	24,8	3,27	7,58	24,2	3,75	6,45	23,7	4,23	5,60	23,2	4,74	4,89	22,8	5,25	4,34	22,2	5,77	3,85
	15	24,6	3,19	7,71	24,0	3,67	6,54	23,5	4,14	5,68	23,0	4,63	4,97	22,6	5,11	4,42	22,0	5,60	3,93
20	24,7	3,11	7,94	24,2	3,56	6,80	23,7	4,02	5,90	23,2	4,46	5,20	22,6	4,91	4,60	22,0	5,35	4,11	
25 kW	-20	16,7	6,63	2,52	16,3	7,03	2,32	16,0	7,48	2,14	15,6	8,43	1,85	15,2	9,44	1,61	14,9	10,3	1,45
	-15	17,1	6,55	2,61	16,7	6,96	2,40	16,4	7,39	2,22	16,0	8,39	1,91	15,6	9,40	1,66	15,2	10,2	1,49
	-10	18,1	6,56	2,76	18,2	7,05	2,58	17,8	7,20	2,47	17,6	8,11	2,17	17,5	9,10	1,92	17,7	9,95	1,78
	-7	19,6	6,67	2,94	19,6	7,18	2,73	19,5	7,19	2,71	19,6	8,13	2,41	19,7	9,16	2,15	19,9	9,94	2,00
	-2	22,5	6,06	3,71	22,0	6,57	3,35	22,0	6,77	3,25	21,9	7,55	2,90	22,1	8,44	2,62	21,8	9,12	2,39
	2	24,5	5,38	4,55	23,9	5,90	4,05	24,1	6,23	3,87	23,8	6,94	3,43	23,9	7,66	3,12	23,2	8,32	2,79
	7	25,7	4,38	5,87	25,2	4,87	5,17	24,8	5,37	4,62	24,8	5,93	4,18	24,8	6,49	3,82	23,7	7,14	3,32
	12	27,7	4,42	6,27	27,2	5,03	5,41	26,3	5,66	4,65	26,5	6,29	4,21	26,3	6,96	3,78	25,2	7,66	3,29
	15	27,7	4,53	6,11	27,1	5,19	5,22	26,5	5,85	4,53	26,4	6,53	4,04	26,2	7,24	3,62	25,1	7,97	3,15
20	27,6	4,52	6,11	27,1	5,24	5,17	26,6	5,96	4,46	26,4	6,72	3,93	26,3	7,45	3,53	25,4	8,25	3,08	
27 kW	-20	17,5	7,03	2,49	17,2	7,43	2,31	16,8	7,88	2,13	16,3	8,96	1,82	15,9	10,0	1,59	15,7	10,9	1,44
	-15	18,0	6,95	2,59	17,6	7,40	2,38	17,3	7,82	2,21	16,8	8,83	1,90	16,3	9,94	1,64	16,0	10,8	1,48
	-10	19,3	6,84	2,82	19,0	7,34	2,59	18,7	7,52	2,49	18,6	8,48	2,19	18,4	9,52	1,93	18,3	10,4	1,76
	-7	21,3	6,96	3,06	21,3	7,47	2,85	21,1	7,55	2,79	20,9	8,50	2,46	20,1	9,42	2,13	20,7	10,3	2,01
	-2	23,9	6,49	3,68	23,8	7,04	3,38	23,6	7,31	3,23	23,7	8,17	2,90	23,6	9,08	2,60	23,2	9,83	2,36
	2	27,1	6,17	4,39	26,5	6,73	3,94	26,3	7,13	3,69	26,2	7,89	3,32	26,0	8,70	2,99	25,6	9,45	2,71
	7	27,9	5,13	5,44	27,4	5,67	4,83	27,0	6,21	4,35	27,2	6,83	3,98	27,3	7,50	3,64	26,8	8,22	3,26
	12	28,8	4,76	6,05	28,3	5,38	5,26	27,7	6,00	4,62	27,9	6,67	4,18	27,8	7,39	3,76	27,1	8,14	3,33
	15	29,1	4,80	6,06	28,5	5,47	5,21	27,8	6,14	4,53	27,8	6,86	4,05	27,7	7,61	3,64	27,1	8,39	3,23
20	29,0	4,75	6,11	28,4	5,50	5,16	27,9	6,21	4,49	28,0	6,98	4,01	28,1	7,74	3,63	27,4	8,59	3,19	

Model SHP290		HEATING																	
		T air outdoor [°C]	Tout [°C]																
			47-55			60			55-65			70			75			78	
Heating capacity [kW]	Power input [kW]	COP [W/W]	Heating capacity [kW]	Power input [kW]	COP [W/W]	Heating capacity [kW]	Power input [kW]	COP [W/W]	Heating capacity [kW]	Power input [kW]	COP [W/W]	Heating capacity [kW]	Power input [kW]	COP [W/W]	Heating capacity [kW]	Power input [kW]	COP [W/W]		
21 kW	-20	12,9	8,59	1,50	12,5	8,99	1,39	-	-	-	-	-	-	-	-	-	-	-	
	-15	13,1	8,45	1,55	12,8	8,89	1,44	-	-	-	-	-	-	-	-	-	-	-	
	-10	15,0	8,21	1,83	15,7	9,29	1,69	15,7	9,70	1,62	-	-	-	-	-	-	-	-	
	-7	16,0	7,97	2,01	17,9	9,68	1,85	18,0	10,0	1,80	16,1	9,82	1,64	-	-	-	-	-	
	-2	18,3	7,52	2,43	19,3	8,94	2,16	19,4	9,34	2,08	18,1	9,68	1,87	17,6	10,3	1,71	-	-	
	2	19,2	6,99	2,75	20,0	8,26	2,42	19,7	8,58	2,30	19,0	9,22	2,06	18,4	9,79	1,88	18,0	10,1	1,78
	7	19,6	6,13	3,20	20,0	7,09	2,82	19,7	7,38	2,67	19,1	7,99	2,39	18,2	8,47	2,15	17,8	8,77	2,03
	12	20,2	5,75	3,51	20,7	6,63	3,12	20,4	6,98	2,92	19,5	7,53	2,59	18,7	8,03	2,33	18,2	8,31	2,19
	15	20,4	5,71	3,57	20,5	6,43	3,19	20,1	6,75	2,98	19,3	7,31	2,64	18,7	7,76	2,41	18,2	8,05	2,26
20	21,0	5,70	3,68	20,5	6,17	3,32	20,0	6,50	3,08	19,2	7,01	2,74	18,5	7,43	2,49	18,0	7,66	2,35	
23 kW	-20	13,8	9,12	1,51	13,2	9,71	1,36	-	-	-	-	-	-	-	-	-	-	-	
	-15	13,9	9,08	1,53	13,6	9,71	1,40	-	-	-	-	-	-	-	-	-	-	-	
	-10	16,1	8,98	1,79	17,0	10,2	1,67	17,0	10,6	1,60	-	-	-	-	-	-	-	-	
	-7	17,8	8,96	1,99	19,3	10,5	1,84	19,5	10,9	1,79	15,4	9,1	1,69	-	-	-	-	-	
	-2	20,0	8,48	2,36	20,8	9,63	2,16	20,8	10,0	2,09	18,1	9,5	1,90	17,5	10,1	1,73	-	-	
	2	21,7	8,10	2,68	21,4	8,81	2,43	21,4	9,16	2,34	19,8	9,6	2,06	19,2	10,2	1,88	18,8	10,5	1,79
	7	21,6	6,79	3,18	21,5	7,60	2,83	21,2	7,97	2,66	20,3	8,64	2,35	19,6	9,16	2,14	19,2	9,50	2,02
	12	22,0	6,18	3,56	21,5	6,85	3,14	21,3	7,23	2,95	20,2	7,83	2,58	19,5	8,33	2,34	19,0	8,64	2,20
	15	21,5	5,99	3,59	21,2	6,60	3,21	20,8	6,96	2,99	19,8	7,56	2,62	19,3	8,04	2,40	18,9	8,33	2,27
20	21,6	5,73	3,77	20,9	6,24	3,35	20,6	6,58	3,13	19,7	7,11	2,77	18,8	7,55	2,49	18,5	7,81	2,37	
25 kW	-20	14,8	10,1	1,47	14,8	9,87	1,50	-	-	-	-	-	-	-	-	-	-	-	
	-15	15,1	10,0	1,51	15,1	9,82	1,54	-	-	-	-	-	-	-	-	-	-	-	
	-10	17,9	9,92	1,80	18,8	11,0	1,71	18,9	11,2	1,69	-	-	-	-	-	-	-	-	
	-7	20,2	9,90	2,04	21,8	12,0	1,82	22,0	11,8	1,86	18,3	10,5	1,74	-	-	-	-	-	
	-2	21,9	9,34	2,34	23,4	11,1	2,11	23,3	11,1	2,10	20,6	10,8	1,91	20,5	11,5	1,78	-	-	
	2	23,1	8,66	2,67	24,4	10,3	2,37	24,0	10,5	2,29	22,8	11,0	2,07	22,1	11,6	1,91	21,6	12,0	1,80
	7	23,2	7,66	3,03	24,5	9,04	2,71	24,1	9,56	2,52	23,2	10,3	2,25	22,4	10,9	2,06	22,0	11,3	1,95
	12	24,9	8,24	3,02	23,9	8,79	2,72	23,7	9,33	2,54	22,6	10,1	2,24	21,8	10,7	2,04	21,4	11,1	

9.2 COOLING

Model SHP290		COOLING																	
		Tout [°C]																	
		5			7			10			12			15			18		
T air outdoor [°C]	Cooling capacity [kW]	Power input [kW]	EER [W/W]	Cooling capacity [kW]	Power input [kW]	EER [W/W]	Cooling capacity [kW]	Power input [kW]	EER [W/W]	Cooling capacity [kW]	Power input [kW]	EER [W/W]	Cooling capacity [kW]	Power input [kW]	EER [W/W]	Cooling capacity [kW]	Power input [kW]	EER [W/W]	
21 kW	10	17,1	2,99	5,72	18,2	2,94	6,19	20,5	2,45	8,37	19,3	2,30	8,39	17,0	2,33	7,30	19,1	1,80	10,6
	20	16,0	3,45	4,64	16,8	3,45	4,87	19,2	3,04	6,32	18,2	2,88	6,32	15,6	3,01	5,18	17,4	2,62	6,64
	25	16,9	3,97	4,26	17,6	3,98	4,42	20,0	3,60	5,56	18,9	3,21	5,89	17,3	3,09	5,60	19,4	2,79	6,95
	30	16,6	4,54	3,66	17,9	4,54	3,94	19,8	4,24	4,67	19,4	3,81	5,09	17,8	3,53	5,04	19,9	3,28	6,07
	35	16,5	5,24	3,15	17,4	5,26	3,31	19,1	5,04	3,79	19,0	4,58	4,15	17,7	4,19	4,22	19,6	4,02	4,88
	40	17,2	6,62	2,60	18,2	6,64	2,74	20,1	6,53	3,08	19,6	5,75	3,41	17,8	4,96	3,59	19,8	4,85	4,08
23 kW	10	18,8	3,12	6,03	20,0	3,06	6,54	22,7	2,68	8,47	21,7	2,37	9,16	19,7	2,43	8,11	22,4	2,11	10,6
	20	17,8	3,66	4,86	18,8	3,64	5,16	21,3	3,35	6,36	20,3	3,01	6,74	18,1	3,06	5,92	20,5	2,83	7,24
	25	18,4	4,32	4,26	19,5	4,30	4,53	21,6	4,06	5,32	20,9	3,59	5,82	18,8	3,36	5,60	21,0	3,16	6,65
	30	18,2	5,04	3,61	19,5	5,05	3,86	21,7	4,85	4,47	21,0	4,26	4,93	19,6	3,81	5,14	21,5	3,65	5,89
	35	17,8	5,86	3,04	18,9	5,89	3,21	21,1	5,77	3,66	20,4	5,09	4,01	19,1	4,49	4,25	21,0	4,38	4,79
	40	18,3	7,41	2,47	19,3	7,45	2,59	21,5	7,44	2,89	20,9	6,39	3,27	19,1	5,37	3,56	21,4	5,27	4,06
25 kW	10	18,5	3,46	5,35	19,6	3,42	5,73	21,7	3,35	6,48	22,1	3,09	7,15	22,6	2,70	8,37	25,1	2,55	9,84
	20	17,3	3,70	4,68	18,5	3,68	5,03	20,6	3,65	5,64	20,7	3,42	6,05	21,4	3,05	7,02	23,7	2,97	7,98
	25	17,7	4,29	4,13	18,7	4,29	4,36	20,8	4,31	4,83	21,7	4,13	5,25	22,6	3,82	5,92	25,0	3,81	6,56
	30	18,5	5,21	3,55	19,5	5,26	3,71	22,0	5,31	4,14	22,4	5,01	4,47	22,9	4,55	5,03	25,5	4,56	5,59
	35	18,6	6,12	3,04	19,8	6,19	3,20	22,2	6,27	3,54	22,3	5,88	3,79	22,6	5,28	4,28	25,3	5,32	4,76
	40	19,0	7,39	2,57	19,9	7,48	2,66	22,1	7,62	2,90	22,4	7,18	3,12	22,4	6,46	3,47	24,5	6,53	3,75
27 kW	10	20,6	3,77	5,46	21,7	3,75	5,79	24,2	3,70	6,54	24,8	3,48	7,13	25,6	3,12	8,21	28,9	2,99	9,67
	20	19,6	4,21	4,66	20,9	4,23	4,94	22,9	4,22	5,43	23,9	4,02	5,95	24,7	3,68	6,71	27,4	3,63	7,55
	25	19,9	4,96	4,01	21,5	4,97	4,33	23,9	5,02	4,76	24,9	4,85	5,13	25,7	4,59	5,60	28,4	4,59	6,19
	30	20,8	6,03	3,45	22,4	6,09	3,68	24,2	6,29	3,85	25,0	6,00	4,17	26,1	5,49	4,75	28,6	5,55	5,15
	35	21,0	7,12	2,95	22,3	7,19	3,10	24,2	7,36	3,29	25,1	6,93	3,62	25,6	6,32	4,05	27,9	6,43	4,34
	40	20,6	8,41	2,45	21,8	8,55	2,55	23,8	8,72	2,73	24,7	8,32	2,97	25,2	7,68	3,28	27,2	7,79	3,49
46	19,0	9,41	2,02	20,3	9,58	2,12	22,2	9,78	2,27	22,6	9,30	2,43	23,2	8,56	2,71	25,1	8,75	2,87	

9.3 DOMESTIC HOT WATER

The tables show the heating capacity, input power and COP values at various outdoor air temperatures during summer for technical water at 45 / 50 / 55 / 60 / 65 / 70 / 75 °C for domestic hot water production. The technical data are indicative and are subject to change. (\*) Data obtained for a water temperature variation of 5°C.

Model SHP290		HEATING																								
		Tout [°C]																								
		45			50			55			60			65			70			75			78			
T air outdoor [°C]	Heating capacity [kW]	Power input [kW]	COP [W/W]	Heating capacity [kW]	Power input [kW]	COP [W/W]	Heating capacity [kW]	Power input [kW]	COP [W/W]	Heating capacity [kW]	Power input [kW]	COP [W/W]	Heating capacity [kW]	Power input [kW]	COP [W/W]	Heating capacity [kW]	Power input [kW]	COP [W/W]	Heating capacity [kW]	Power input [kW]	COP [W/W]	Heating capacity [kW]	Power input [kW]	COP [W/W]		
21 kW	20	22,1	4,92	4,49	21,6	5,35	4,04	20,9	5,76	3,63	20,5	6,17	3,32	19,8	6,60	3,00	19,2	7,01	2,74	18,5	7,43	2,49	18,0	7,66	2,35	
	25	22,1	4,70	4,70	21,5	4,94	4,35	20,8	5,27	3,95	20,0	5,63	3,55	19,3	5,98	3,23	18,7	6,30	2,97	18,0	6,64	2,71	17,6	6,85	2,57	
	30	23,1	4,44	5,20	22,6	4,55	4,97	21,8	4,82	4,52	21,0	5,22	4,02	20,4	5,54	3,68	19,7	5,86	3,36	19,1	6,18	3,09	18,6	6,37	2,92	
	35	24,3	4,18	5,81	23,7	4,15	5,71	22,8	4,38	5,21	21,9	4,80	4,56	21,3	5,11	4,17	20,7	5,40	3,83	20,0	5,71	3,50	19,6	5,89	3,33	
	40	25,4	4,17	6,09	24,9	4,16	5,99	24,1	4,40	5,48	23,3	4,84	4,81	22,4	4,35	5,15	21,8	5,46	3,99	-	-	-	-	-	-	-
	45	26,8	4,16	6,44	26,3	4,16	6,32	25,1	4,41	5,69	24,7	4,87	5,07	23,9	5,20	4,60	-	-	-	-	-	-	-	-	-	-
23 kW	20	22,6	4,91	4,60	22,0	5,35	4,11	21,5	5,80	3,71	20,9	6,24	3,35	20,3	6,68	3,04	19,7	7,11	2,77	18,8	7,55	2,49	18,5	7,81	2,37	
	25	23,0	5,15	4,47	22,4	5,59	4,01	21,8	6,02	3,62	21,2	6,44	3,29	20,5	6,88	2,98	19,8	7,31	2,71	19,1	7,73	2,47	18,7	7,96	2,35	
	30	24,1	4,73	5,10	23,4	4,89	4,79	22,8	5,22	4,37	22,0	5,68	3,87	21,5	6,07	3,54	20,8	6,46	3,22	20,1	6,86	2,93	19,7	7,09	2,78	
	35	25,2	4,31	5,85	24,5	4,20	5,83	23,8	4,42	5,38	23,1	4,91	4,70	22,4	5,26	4,26	21,7	5,61	3,87	21,0	5,95	3,53	20,5	6,16	3,33	
	40	26,3	4,29	6,13	25,7	4,19	6,13	25,0	4,43	5,64	24,4	4,93	4,95	23,9	5,30	4,51	22,9	5,65	4,05	-	-	-	-	-	-	-
	45	27,8	4,26	6,53	27,0	4,18	6,46	26,2	4,43	5,91	25,4	4,94	5,14	25,0	5,32	4,70	-	-	-	-	-	-	-	-	-	-
25 kW	20	26,3	7,45	3,53	25,4	8,25	3,08	24,9	9,02	2,76	23,6	9,22	2,56	23,0	10,0	2,30	22,4	10,7	2,09	21,8	11,4	1,91	21,4	11,8	1,81	
	25	26,9	6,78	3,97	25,9	7,58	3,42	25,1	8,24	3,05	23,4	8,35	2,80	22,7	9,10	2,49	22,1	9,79	2,26	21,4	10,5	2,04	21,0	10,8	1,94	
	30	28,6	6,70	4,27	27,4	7,54	3,63	26,4	8,23	3,21	24,5	8,35	2,93	23,8	9,13	2,61	23,1	9,84	2,35	22,5	10,5	2,14	22,1	10,9	2,03	
	35	30,1	6,62	4,55	28,8	7,49	3,85	27,6	8,20	3,37	25,6	8,35	3,07	24,9	9,14	2,72	24,2	9,88	2,45	23,4	10,6	2,21	23,0	11,0	2,09	
	40	31,6	6,54	4,83	30,2	7,43	4,06	29,1	8,17	3,56	26,9	8,34	3,23	26,1	9,16	2,85	25,3	9,92	2,55	-	-	-	-	-	-	-
	45	33,1	6,45	5,13	31,8	7,37	4,31	30,5	8,14	3,75	28,3	8,33	3,40	27,5	9,18	3,00	-	-	-	-	-	-	-	-	-	-
27 kW	20	28,1	7,74	3,63	27,4	8,59	3,19	26,8	9,34	2,87	24,4	9,24	2,64	23,9	9,96	2,40	23,3	10,6	2,20	22,5	11,3	1,99	22,2	11,8	1,88	
	25	27,9	6,77	4,12	27,2	7,59	3,58	26,7	8,36	3,19	24,3	8,38	2,90	23,8	9,08	2,62	23,1	9,70	2,38	22,3	10,4	2,14	22,0	10,9	2,02	
	30	29,6	6,69	4,42	28,7	7,54	3,81	28,0	8,34	3,36	25,4	8,38	3,03	24,8	9,10	2,73	24,2	9,74	2,48	23,3	10,4	2,24	23,0	10,9	2,11	
	35	31,1	6,61	4,70	30,1	7,49	4,02	29,3	8,32	3,52	26,5	8,37	3,17	25,8	9,11	2,83	25,2	9,77	2,58	24,3	10,5	2,31	24,0	11,0	2,18	
	40	32,6	6,53	4,99	31,5	7,44	4,23	30,7	8,28	3,71	27,8	8,36	3,33	27,1	9,13	2,97	26,3	9,81	2,68	-	-	-	-	-	-	-
	45	34,2	6,44	5,31	33,0	7,39	4,47	32,2	8,25	3,90	29,1	8,35	3,49	28,4	9,14	3,11	-	-	-	-	-	-	-	-	-	-

9.4 PERFORMANCE TABLES AT MINIMUM CAPACITY

The following tables show the minimum capacity, power input and efficiency values for different outside air and water outlet temperatures. The data are useful to understand the minimum partialization of the heat pump and are essential for the correct choice of unit. Failure to meet the minimum load at the heat pump results in intermittent operation with high restarts and a reduction in the useful compressor life. The data are obtained with fixed flow rate (balancing the system at the minimum guaranteed by the partialization of the pump at the nominal point) and with fixed Tout for 35/45/55/65 °C (in heating) and 7/18 °C (in cooling). The heat data also take in account any defrosting.

HEATING - MINIMUM CAPACITY													
Model SHP290	T air outdoor [°C]	Tout [°C]											
		35			45			55			65		
		Heating capacity [kW]	Power input [kW]	COP [W/W]	Heating capacity [kW]	Power input [kW]	COP [W/W]	Heating capacity [kW]	Power input [kW]	COP [W/W]	Heating capacity [kW]	Power input [kW]	COP [W/W]
21 kW	-20	5,18	2,89	1,79	4,98	3,23	1,54	4,87	3,69	1,32	-	-	-
	-15	6,07	2,95	2,06	5,80	3,33	1,74	5,62	3,80	1,48	-	-	-
	-10	7,23	2,85	2,54	7,11	3,34	2,13	6,91	3,85	1,79	7,27	4,62	1,57
	-7	8,20	2,80	2,93	8,05	3,34	2,41	7,86	3,89	2,02	8,61	4,90	1,76
	-2	9,84	2,78	3,54	9,49	3,33	2,85	9,10	3,88	2,35	9,59	4,83	1,99
	2	10,8	2,63	4,11	10,5	3,21	3,27	10,0	3,73	2,68	10,1	4,57	2,21
	7	12,6	2,47	5,10	12,1	3,05	3,97	11,4	3,58	3,18	11,2	4,27	2,62
	12	14,5	2,47	5,87	13,9	3,11	4,47	12,9	3,61	3,57	12,6	4,30	2,93
	15	15,1	2,54	5,94	14,4	3,18	4,53	13,6	3,71	3,67	13,0	4,34	3,00
20	16,8	2,71	6,20	16,0	3,35	4,78	15,1	3,97	3,80	14,3	4,58	3,12	
23 kW	-20	5,34	2,97	1,80	5,09	3,31	1,54	5,06	3,70	1,37	-	-	-
	-15	6,23	3,05	2,04	6,01	3,43	1,75	5,85	3,84	1,52	-	-	-
	-10	7,48	2,89	2,59	7,18	3,35	2,14	6,97	3,81	1,83	7,35	4,53	1,62
	-7	8,38	2,80	2,99	8,32	3,33	2,50	7,75	3,81	2,03	8,44	4,65	1,82
	-2	9,93	2,82	3,52	9,73	3,37	2,89	9,34	3,93	2,38	9,68	4,67	2,07
	2	11,1	2,68	4,14	10,8	3,26	3,31	10,5	3,87	2,71	10,4	4,51	2,31
	7	12,8	2,47	5,18	12,4	3,08	4,03	12,0	3,66	3,28	11,7	4,33	2,70
	12	14,7	2,38	6,18	14,1	3,03	4,65	13,5	3,65	3,70	13,0	4,32	3,01
	15	15,3	2,42	6,32	14,6	3,07	4,76	13,8	3,69	3,74	13,2	4,33	3,05
20	16,9	2,56	6,60	16,0	3,22	4,97	15,3	3,85	3,97	14,4	4,46	3,23	
25 kW	-20	5,57	3,08	1,81	5,26	3,86	1,36	5,11	4,15	1,23	-	-	-
	-15	6,54	3,16	2,07	6,20	4,01	1,55	6,05	4,30	1,41	-	-	-
	-10	7,92	3,20	2,48	7,65	4,03	1,90	7,81	4,38	1,78	8,30	4,97	1,67
	-7	8,87	3,11	2,85	8,93	3,98	2,24	8,90	4,30	2,07	9,85	5,15	1,91
	-2	10,8	3,08	3,51	10,7	3,87	2,76	10,4	4,30	2,42	11,0	5,13	2,14
	2	12,3	2,93	4,20	12,0	3,67	3,27	11,4	4,17	2,73	11,7	5,05	2,32
	7	14,0	2,77	5,05	13,9	3,42	4,06	12,7	4,04	3,14	12,9	4,98	2,59
	12	15,7	3,05	5,15	15,6	3,84	4,06	15,0	4,78	3,14	14,5	5,62	2,58
	15	16,4	3,24	5,06	16,1	4,11	3,92	15,5	5,14	3,02	14,9	6,00	2,48
20	17,9	3,46	5,17	17,7	4,48	3,95	17,2	5,73	3,00	16,3	6,66	2,45	
27 kW	-20	5,65	3,07	1,84	5,35	3,87	1,38	5,28	4,15	1,27	-	-	-
	-15	6,67	3,16	2,11	6,34	4,01	1,58	6,23	4,34	1,44	-	-	-
	-10	8,24	3,20	2,58	7,95	4,03	1,97	7,76	4,46	1,74	7,98	5,00	1,60
	-7	9,43	3,23	2,92	9,06	4,06	2,23	8,97	4,60	1,95	9,23	5,32	1,73
	-2	11,2	3,25	3,45	11,1	4,03	2,75	10,7	4,60	2,33	10,4	5,29	1,97
	2	12,5	3,07	4,07	12,3	3,79	3,25	11,9	4,39	2,71	11,7	5,16	2,27
	7	14,1	2,86	4,93	14,1	3,53	3,99	13,4	4,21	3,18	12,9	5,03	2,56
	12	16,0	3,02	5,30	15,9	3,82	4,16	15,4	4,69	3,28	14,8	5,51	2,69
	15	16,6	3,17	5,24	16,3	4,04	4,03	16,0	5,03	3,18	15,2	5,87	2,59
20	17,9	3,34	5,36	18,0	4,31	4,18	17,8	5,60	3,18	16,5	6,39	2,58	

COOLING - MINIMUM CAPACITY							
Model SHP290	T air outdoor [°C]	Tout [°C]					
		5			7		
		Cooling capacity [kW]	Power input [kW]	EER [W/W]	Cooling capacity [kW]	Power input [kW]	EER [W/W]
21 kW	10	11,0	1,62	6,79	16,6	1,47	11,3
	20	10,1	1,96	5,15	15,1	1,95	7,75
	25	9,68	2,07	4,68	14,8	2,05	7,22
	30	9,35	2,31	4,05	14,1	2,23	6,32
	35	8,82	2,64	3,34	13,2	2,63	5,02
	40	7,98	3,01	2,65	12,0	2,98	4,03
23 kW	10	10,8	1,47	7,35	17,2	1,45	11,9
	20	10,2	1,81	5,64	15,7	2,01	7,81
	25	9,75	1,99	4,90	14,7	2,07	7,10
	30	9,28	2,30	4,03	14,0	2,26	6,19
	35	8,76	2,67	3,28	13,1	2,63	4,98
	40	7,83	3,10	2,53	12,1	3,00	4,03
25 kW	10	13,5	2,21	6,11	19,7	1,83	10,8
	20	12,8	2,38	5,38	18,6	2,15	8,65
	25	12,0	2,54	4,72	17,8	2,44	7,30
	30	11,2	2,81	3,99	17,2	2,73	6,30
	35	10,7	3,12	3,43	16,4	3,24	5,06
	40	9,94	3,66	2,72	14,7	3,72	3,95
27 kW	10	9,34	4,09	2,28	13,5	4,17	3,24
	20	12,1	1,92	6,30	18,2	1,62	11,2
	25	11,7	2,18	5,37	17,3	1,99	8,69
	30	11,3	2,39	4,73	16,4	2,30	7,13
	35	10,7	2,68	3,99	15,8	2,67	5,92
	40	10,1	3,05	3,31	14,9	3,18	4,69
27 kW	40	9,31	3,61	2,58	13,6	3,70	3,68
	46	8,73	4,10	2,13	12,6	4,22	2,99

10. SEASONAL PERFORMANCE AT DIFFERENT TEMPERATURE LEVELS

The values of the seasonal performance coefficients SCOP, heating energy efficiency  $\eta_{s,h}$  and design heat output  $P_{design}$  for the SHP290 series units are shown. The data are calculated for three temperature levels according to UNI EN 14825: low (LT), medium (MT) and high (HT).

- LT: Heating in medium climate conditions, T<sub>biv</sub>= -7 °C, low temperature (35 °C), variable output, fixed flow rate.
- MT: Heating in medium climate conditions, T<sub>biv</sub>= -7 °C, medium temperature (55 °C), variable output, fixed flow rate.
- HT: Heating in medium climate conditions, T<sub>biv</sub>= -7 °C, high temperature (65 °C), variable output, fixed flow rate.

Model SHP290	Pdesign (LT) kW	SCOP (LT) W/W	$\eta_{s,h}$ (LT) %	Pdesign (MT) kW	SCOP (MT) W/W	$\eta_{s,h}$ (MT) %	Pdesign (HT) kW	SCOP (HT) W/W	$\eta_{s,h}$ (HT) %
21 kW	20	4,75	187	19	3,70	145	20	3,28	128
23 kW	21	4,72	186	21	3,74	147	22	3,25	127
25 kW	22	4,49	177	22	3,66	143	25	3,20	125
27 kW	24	4,46	175	23	3,56	140	25	3,21	125

**11. DATA FOR THE ENERGY CERTIFICATION OF BUILDINGS ACCORDING TO UNI/TS 11300-4 FOR HEAT PUMPS**

The supplementary data of heat pumps for the calculation of the energy performance of buildings according to UNI/TS 11300 part 4 are given below.

The characteristics quantities that will be provided for each model are explained below, according to statement 30 of the standard.

	E	A T <sub>bival</sub>	B	C	D
Reference temperature	-10 °C	-7 °C	2 °C	7 °C	12 °C
PLR (T <sub>des</sub> = -10°C)	100%	88%	54%	35%	15%
Power DC at full load		DC <sub>A</sub> = DC <sub>bival</sub>	DC <sub>B</sub>	DC <sub>C</sub>	DC <sub>D</sub>
COP at partial load		COP <sub>A</sub>	COP <sub>B</sub>	COP <sub>C</sub>	COP <sub>D</sub>
COP at full load		COP'A	COP'B	COP'c	COP'D
CR	>1	1	(0,54 x P <sub>des</sub> ) / DC <sub>B</sub>	(0,35 x P <sub>des</sub> ) / DC <sub>C</sub>	(0,15 x P <sub>des</sub> ) / DC <sub>D</sub>
Correction factor F <sub>p</sub>	1	1	COP <sub>B</sub> /COP'B	COP <sub>C</sub> /COP'c	COP <sub>D</sub> /COP'D
PLR	part load ratio - climatic load factor				
CR	heat pump load factor				
DC	full load power at indicated temperatures				
DC <sub>bival</sub>	full load power at -7/35°C				
P <sub>design</sub>	full load with temperate climate				
COP	COP with CR load at the same temperature conditions as COP'				
COP'	COP at full load under the same temperature conditions as COP				

**Model SHP290 21 kW**

**Operating limits**

COLD source:		OUTDOOR AIR	
Operating temperature (cut-off)		min	-20 °C
		max	20 °C

HOT source:		WATER	
Operating temperature (cut-off)		min	20 °C
		max	78 °C

**Performance data measured in partial load conditions, according to UNI/TS 11300-4**

Operating conditions		A T <sub>bival</sub>	B	C	D
Reference temperature	[°C]	-7	2	7	12
PLR (T <sub>des</sub> = -10°C)	[%]	88	54	35	15
Power DC at full load	[kW]	17,3	20,5	21,0	22,0
COP at partial load		2,86	4,11	5,32	5,71
COP at full load		2,86	4,06	4,87	5,51
CR		1,00	1,00	0,74	0,28
Corrective factor F <sub>p</sub>		1,00	1,01	1,09	1,04

**Model SHP290 23 kW**

**Operating limits**

COLD source:		OUTDOOR AIR	
Operating temperature (cut-off)		min	-20 °C
		max	20 °C

HOT source:		WATER	
Operating temperature (cut-off)		min	20 °C
		max	78 °C

**Performance data measured in partial load conditions, according to UNI/TS 11300-4**

Operating conditions		A T <sub>bival</sub>	B	C	D
Reference temperature	[°C]	-7	2	7	12
PLR (T <sub>des</sub> = -10°C)	[%]	88	54	35	15
Power DC at full load	[kW]	18,6	22,8	22,8	23,7
COP at partial load		2,75	3,89	5,30	5,73
COP at full load		2,75	3,87	4,77	5,63
CR		1,00	1,00	0,79	0,31
Corrective factor F <sub>p</sub>		1,00	1,00	1,11	1,02

**Model SHP290 25 kW**

**Operating limits**

COLD source:		OUTDOOR AIR	
Operating temperature (cut-off)		min	-20 °C
		max	20 °C

HOT source:		WATER	
Operating temperature (cut-off)		min	20 °C
		max	78 °C

**Performance data measured in partial load conditions, according to UNI/TS 11300-4**

Operating conditions		A T <sub>bival</sub>	B	C	D
Reference temperature	[°C]	-7	2	7	12
PLR (T <sub>des</sub> = -10°C)	[%]	88	54	35	15
Power DC at full load	[kW]	19,6	23,9	24,8	26,5
COP at partial load		2,71	3,94	5,09	5,63
COP at full load		2,71	3,83	4,62	4,72
CR		1,00	1,00	0,75	0,30
Corrective factor F <sub>p</sub>		1,00	1,03	1,10	1,19

**Model SHP290 27 kW**

**Operating limits**

COLD source:		OUTDOOR AIR	
Operating temperature (cut-off)		min	-20 °C
		max	20 °C

HOT source:		WATER	
Operating temperature (cut-off)		min	20 °C
		max	78 °C

**Performance data measured in partial load conditions, according to UNI/TS 11300-4**

Operating conditions		A T <sub>bival</sub>	B	C	D
Reference temperature	[°C]	-7	2	7	12
PLR (T <sub>des</sub> = -10°C)	[%]	88	54	35	15
Power DC at full load	[kW]	21,0	26,1	27,0	27,7
COP at partial load		2,77	3,95	4,91	5,63
COP at full load		2,77	3,66	4,35	4,64
CR		1,00	1,00	0,82	0,31
Corrective factor F <sub>p</sub>		1,00	1,08	1,13	1,21

**11.1 EER DATATO CALCULATE THE ENERGY PERFORMANCE OF BUILDINGS, ACCORDING TO UNI/TS 11300-3**

The EER coefficients under partial load conditions for i-290 reversible heat pumps are provided. The conditions of reference under partial load specified by standard UNI/TS 11300-3 for air-water reversible chillers and heat pumps are shown below. The EER are also provided for load factors lower than 25%.

Test	Load factor	Outdoor air dry bulb temperature	Chilled water temperature on fan coil input/output
1	100%	35	12/7
2	75%	30	(*)/7
3	50%	25	(*)/7
4	25%	20	(*)/7

(\*) temperature set by the full load water flow rate:

**Model SHP290 21 kW**

Outdoor air dry bulb temperature [°C]	Load factor F%	EER	Cooling capacity [kW]
35	100%	3,31	17,4
30	75%	4,23	13,1
25	50%	5,19	8,7
20	25%	5,38	8,3

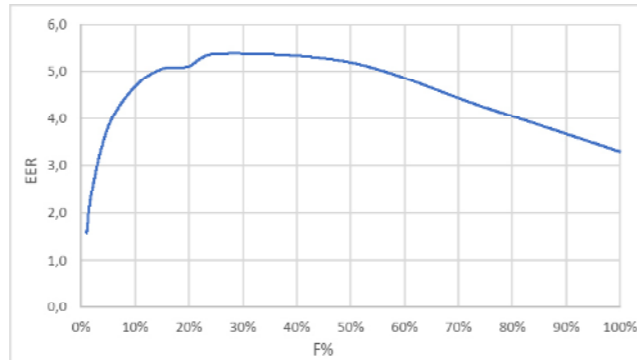

C	Load factor F%	EER @20°C x C
0,95	20%	5,11
0,94	15%	5,05
0,87	10%	4,68
0,71	5%	3,82
0,46	2%	2,47
0,29	1%	1,56

**Model SHP290 23 kW**

Outdoor air dry bulb temperature [°C]	Load factor F%	EER	Cooling capacity [kW]
35	100%	3,21	18,9
30	75%	4,06	14,0
25	50%	5,09	9,5
20	25%	5,55	8,5

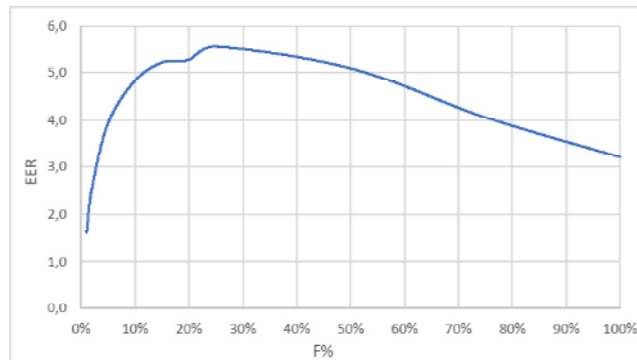

C	Load factor F%	EER @20°C x C
0,95	20%	5,27
0,94	15%	5,21
0,87	10%	4,82
0,71	5%	3,94
0,46	2%	2,55
0,29	1%	1,61

**Model SHP290 25 kW**

Outdoor air dry bulb temperature [°C]	Load factor F%	EER	Cooling capacity [kW]
35	100%	3,20	19,8
30	75%	4,11	14,0
25	50%	4,75	9,9
20	25%	4,73	8,5

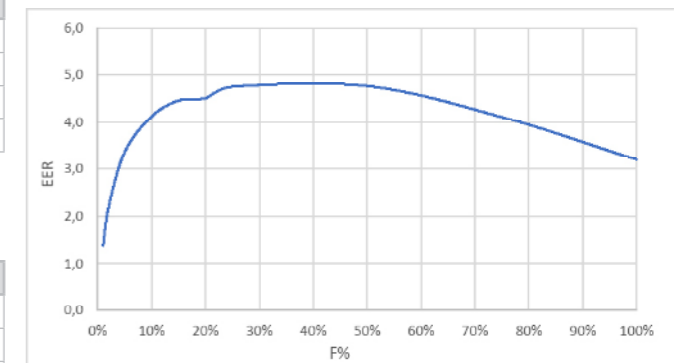

C	Load factor F%	EER @20°C x C
0,95	20%	4,50
0,94	15%	4,45
0,87	10%	4,12
0,71	5%	3,36
0,46	2%	2,18
0,29	1%	1,37

**Model SHP290 27 kW**

Outdoor air dry bulb temperature [°C]	Load factor F%	EER	Cooling capacity [kW]
35	100%	3,10	22,3
30	75%	4,13	16,7
25	50%	4,72	11,2
20	25%	4,90	8,7

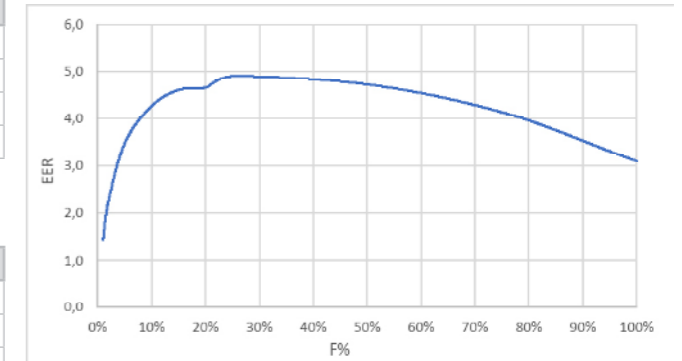

C	Load factor F%	EER @20°C x C
0,95	20%	4,65
0,94	15%	4,60
0,87	10%	4,26
0,71	5%	3,48
0,46	2%	2,25
0,29	1%	1,42

## 12. REFRIGERANT SAFETY DATA SHEET

Name:	R290
<b>HAZARDS IDENTIFICATION</b>	
Main hazards:	Highly flammable gas. Vapours are heavier than air and can cause asphyxiation due to reduced oxygen levels.
Specific hazards:	Contact with the liquid can cause frost burns.
<b>FIRST AID MEASURES</b>	
General information:	In high concentrations it can cause asphyxia. Symptoms may include loss of mobility and/or consciousness. In low concentrations it may have a narcotic effect.
Inhalation:	Move the victim to an uncontaminated area while wearing self-contained breathing apparatus. Use oxygen or artificial respiration artificial respiration if necessary. Keep the patient lying down and warm. Call a doctor.
Eye contact:	Carefully rinse with plenty of water for at least 15 minutes.
Skin contact:	Wash immediately with plenty of water for at least 15 minutes. Immediately remove contaminated clothing.
<b>FIRE FIGHTING MEASURES</b>	
Extinguishing media:	Water spray, dry powder.
Specific hazards:	Exposure to flames may cause the vessel to rupture or explode.
Specific methods:	Cool down the containers with a water spray from a safe position. Stop the product leakage if possible. Use water spray, if possible, to abate the fumes. Move the vessels away from the area of the fire if this can be done without posing any risks.
<b>ACCIDENTAL RELEASE MEASURES</b>	
Personal precautions:	Try to stop the leak. Evacuate personnel to safety areas. Eliminate the ignition sources. Ensure proper ventilation. Avoid entering sewers, basements, excavations and areas where accumulation can be dangerous. Use personal protective equipment. Remain upwind.
Environmental precautions:	Try to stop the leak.
Cleaning methods:	Ventilate the area.
<b>HANDLING AND STORAGE</b>	
Handling: Technical measures/precautions:	Ensure sufficient air exchange and/or suction in the working area. Do not smoke. Keep away from sources of ignition (including electrostatic charges). Use only appropriate equipment, suitable for the product.
Advice for safe use:	Do not inhale the gas.
Storage:	Close carefully and store in a cool and well ventilated area. Storage containers should be checked periodically. Do not store with other oxidants in general or other combustible substances. Containers must not be stored in conditions that could lead to corrosion. All electrical equipment in the storage area are compliant with the risk of explosive atmospheres formation.
<b>EXPOSURE CONTROLS/PERSONAL PROTECTION</b>	
Control parameters:	OEL: data not available. DNEL: data not available. PNEC: data not available.
Respiratory protection:	Filter masks can be used if the ambient conditions and duration of use are known.
Eye protection:	Safety goggles.
Hand protection:	Work gloves.
Hygienic measures:	No smoking.
<b>PHYSICAL AND CHEMICAL PROPERTIES</b>	
Colour:	Colourless.
Odour:	Odourless.
Boiling point:	-42,1 °C at atm press
Flash point:	470°C
Relative gas density (air=1)	1,50
Relative liquid density (water=1)	0,58
Solubility in water:	75 mg/l.
<b>STABILITY AND REACTIVITY</b>	
Stability:	Stable under normal conditions.
Materials to avoid: Decomposition products hazardous:	Air, oxidising agents . Keep away from heat sources/sparks/open flames/heated surfaces. Under normal conditions of storage and use, dangerous decomposition products should not be generated.
<b>TOXICOLOGICAL INFORMATION</b>	
Acute toxicity:	CL50/inhalation/4 hours/on rat = 20000 ppm.
Local effects:	No known effect.
Long term toxicity:	No known effect.
<b>ENVIRONMENTAL INFORMATION</b>	
Global warming potential GWP (R744=1):	0,02
Ozone Depletion Potential ODP (R11=1):	0
Disposal consideration:	Refer to the supplier's gas recovery programme. Avoid direct discharge into the atmosphere. Do not discharge where accumulation can be dangerous. Ensure that the emissions limits required by local regulations or specified in authorizations are not exceeded.

**SAPPHIRE HEAT SOLUTIONS**

5 Howard Road, Eaton Socon, St Neots,  
Cambs, PE19 8ET

Tel. 01480 477066

E-mail: [sales@sapphireheatsolutions.co.uk](mailto:sales@sapphireheatsolutions.co.uk)

[www.sapphireheatsolutions.co.uk](http://www.sapphireheatsolutions.co.uk)