



Air to water heat pumps

# Installer manual

## Models

SHP290 40 kW

SHP290 50 kW



This manual has been created for informative purpose. The company declines any responsibility for the results of any projecting or any installation based on the explanations and/or on the technical specifications provided in this manual. It is besides forbidden the reproduction under any form of the texts of the figures contained in this manual. The data in this manual are not binding and may be changed by the manufacturer without prior notice. Manual in original language. Even partial reproduction PROHIBITED © - EOGB Energy Products Ltd





00	12-2023	E.G. - AL.B.	A.R.	First issue
Rev	Data	Author	Approved	Note
Catalogo / Catalogue / Katalog / Catalogue				Serie / Series / Serie / Serie / Série
MUI02070120000_00				Inverter air/water heat pumps with axial fans



## Contents

1. PURPOSE AND CONTENTS OF THE MANUAL .....	6
1.1 HOW TO KEEP THE MANUAL .....	6
1.2 GRAPHIC SYMBOLS USED IN THE MANUAL .....	6
2. NORMATIVE REFERENCES.....	6
3. PERMITTED USE.....	7
4. GENERAL SAFETY REGULATIONS.....	7
4.1 WORKERS' HEALTH AND SAFETY.....	8
4.2 PERSONAL PROTECTIVE EQUIPMENT.....	8
4.3 SAFETY SIGNS.....	9
4.4 WARNING LABELS.....	9
4.5 REFRIGERANT SAFETY DATA SHEET .....	10
4.6 SPECIFIC R290 GAS WARNINGS.....	11
4.7 INDICATIONS FOR VACUUM AND CHARGE WITH R290 GAS.....	11
4.8 R290 GAS DISPOSAL .....	11
4.9 SAFETY RULES FOR R290 UNITS TRANSPORT AND STORAGE .....	11
5. INSTALLATION .....	12
5.1 GENERAL .....	12
5.2 TRANSPORT AND STORAGE TEMPERATURE LIMITS.....	13
5.3 LIFTING AND HANDLING.....	13
5.3.1 Lifting mode .....	14
5.3.2 Damage to the unit.....	14
5.4 POSITIONING AND MINIMUM TECHNICAL CLEARANCES.....	14
5.5 DANGER AND SAFETY ZONES .....	16
5.5.1 Free-field ground installation .....	17
5.5.2 Ground installation in front of a wall.....	17
5.5.3 Ground installation in a corner.....	18
5.5.4 Flat roof installation .....	19
5.5.5 Multiple installation .....	19
5.6 DIMENSIONS.....	20
5.6.1 Standard version.....	20
5.6.2 Version with tank kit.....	20
5.7 POSITIONING OF CENTRE OF GRAVITY AND VIBRATION DAMPERS .....	21
5.8 ACCESS TO THE INNER PART .....	22
5.8.1 Access to the inside of the unit on the electrical panel side .....	22
5.8.2 Access to the inside of the unit on the hydronic kit side.....	23
5.8.3 Thermostat position and temperature probe .....	23
5.9 MACHINE CHARGING PROCEDURE.....	24
5.10 PLUMBING CONNECTIONS .....	25
5.10.1 Characteristics of the circuit water.....	26
5.10.2 Hydraulic diagram inside the unit .....	26
5.10.3 Condensation discharge system .....	28
5.10.4 System load .....	28
5.10.5 System discharge.....	28



- 5.10.6 Service sleeves ..... 29
- 5.11 FUNCTIONAL DIAGRAMS..... 29
- 5.12 ELECTRICAL CONNECTIONS..... 30
  - 5.12.1 Access to electric panel ..... 31
  - 5.12.2 Power supply ..... 32
  - 5.12.3 Protection devices ..... 32
  - 5.12.4 User terminal block ..... 32
  - 5.12.5 Refrigerant gas leak detection sensor ..... 33
  - 5.12.6 Control logics..... 35
  - 5.12.7 Fuses..... 35
- 5.13 EXTERNAL MODULE (GI3) ..... 35
  - 5.13.1 NET DIMENSIONS AND WITH PACKAGING ..... 35
  - 5.13.2 Technical data..... 36
  - 5.13.3 Installation of external kit (GI3)..... 36
- 6. STARTUP ..... 38
  - 6.1 SWITCHING ON THE UNIT..... 38
- 7. INSTRUCTIONS FOR THE USER ..... 38
- 8. SHUTDOWNS FOR LONG PERIODS..... 39
- 9. MAINTENANCE AND PERIODIC CHECKS ..... 39
  - 9.1 GENERALITY ..... 41
    - 9.1.1 Cleaning the filled coil treated with the anti-corrosion method ..... 41
  - 9.2 CLEANING OF EXTERNAL SURFACES ..... 41
    - 9.2.1 Sensor calibration..... 41
- 10. DECOMMISSIONING..... 42
- 11. RESIDUAL RISKS ..... 42
- 12. TECHNICAL DATA ..... 47
  - 12.1 TECHNICAL DATA SHEET UNIT ..... 47
  - 12.2 UNIT AND AUXILIARY ELECTRICAL DATA ..... 51
- 13. OPERATING LIMITS..... 51
  - 13.1 EVAPORATOR WATER FLOW RATE..... 51
  - 13.2 COLD WATER PRODUCTION (SUMMER MODE) ..... 51
  - 13.3 HOT WATER PRODUCTION (WINTER MODE) ..... 51
  - 13.4 AMBIENT AIR TEMPERATURE AND SUMMERY TABLE ..... 51
- 14. USER INTERFACE - CONTROLLER..... 54
  - 14.1 MENU..... 55
  - 14.2 SETPOINT MENU..... 55
  - 14.3 ALARM MENU [ERR] ..... 55
- 15. TROUBLESHOOTING..... 56



The manual of the SHP290 units, contains all the necessary information for optimal use of the equipment under safe conditions for the operator.

## 1. PURPOSE AND CONTENTS OF THE MANUAL

This manual provides basic information as to the selection, installation, operation and maintenance of the SHP290 unit. It is intended for the operators of the appliance and it enables them to use the equipment efficiently, even if they do not have any previous specific knowledge.

	<b>CAUTION: Although this manual is designed for the end user, some of the operations described are only be carried out by-qualified personnel who have completed technical or skilled manual training to perform this particular work. They must also keep themselves properly updated with courses recognised by the competent authorities. These tasks include: installation, routine and extraordinary maintenance, decommissioning of the appliance and any other operation indicated “by qualified personnel”.</b>
	<b>When installation and/or maintenance operations are completed, the qualified operator must correctly inform the end user regarding the use and the necessary routine maintenance of the appliance.</b>
	<b>It is the responsibility of the operator to submitting all of the documentation necessary (including this manual) and of explaining that it all must be kept carefully, in the vicinity of the appliance and always available.</b>

The manual describes the machine at the moment it was sold. It must therefore be considered adequate with respect to the state-of-the-art in terms of potentiality, ergonomics, safety and functionality.

The company also performs technological upgrades and does not consider itself obliged to update the manuals of previous machine versions which could even be incompatible. Please refer to the manual supplied with the unit installed.

It is recommended to follow the instructions contained in this manual, especially those concerning safety and routine maintenance.

### 1.1 HOW TO KEEP THE MANUAL

The manual must always be present with the machine to which it refers. It must be placed in a safe place, protected from dust, humidity and easily accessible to the operator, who must necessarily consult it in case of doubt about the use of the machine.

The company also makes technological improvements and is not obliged to update machine manuals of previous versions that may be incompatible. We also decline any responsibility for possible inaccuracies in the manual if due to printing or transcription errors.

Any updates that are sent to the customer must be kept as an annex to this manual.

For further detailed information regarding this manual and the unit's use and maintenance, you can refer directly to EOGB Energy Products Ltd

### 1.2 GRAPHIC SYMBOLS USED IN THE MANUAL

	Indicates potentially hazardous situation for people and/or the proper functioning of the unit.
	Indicates prohibited operations.
	Indicates important information that the operator has to follow in order to guarantee the correct operation of the unit in complete safety.

## 2. NORMATIVE REFERENCES

The units i-290 are designed in compliance with the following directives and harmonized standards on the safety of machinery:

- Community directives 2014/68/UE, 2006/42/EC, 2014/30/UE
- Norms EN 378-1:2016 + A1:2020, EN 378-2:2016, EN 378-3:2016 + A1:2020, EN 378-4:2016 + A1:2019
- Norms UNI EN ISO 12100:2010, ISO/TR 14121-2:2012, UNI EN ISO 13857:2020, EN ISO 14120:2015
- Norms EN IEC 61000-6-2:2019, EN IEC 61000-6-4:2019, EN IEC 61000-6-8:2020, EN IEC 61000-3-11:2019, EN 61000-3-12:2011
- Norms EN 12735-1:2020, EN 12735-2:2016, EN 14276-1:2020, EN 14276-2:2020, EN ISO 13585:2012, UNI EN 13134:2002
- Norms EN 60204-1:2018, EN 62233:2008 + AC:2008

And the following directives, regulations and standards on ecodesign and energy labelling:

- Community directive 2009/125/CE and subsequent transpositions
- UE Regulation 2017/1369
- UE Regulation n.811/2013
- UE Regulation n.813/2013
- Norms EN 14511-1:2022, EN 14511-2:2022, EN 14511-3:2022, EN 14511-4:2022
- Norms EN 14825:2022
- Norm UNI EN ISO 9614-1:2009



### 3. PERMITTED USE

- The company excludes any contractual and extra contractual liability for damage caused to persons, animals or objects, by incorrect installation, setting and maintenance, improper use of the equipment, and the partial or superficial reading of the information contained in this manual.
- These units are built for the heating and/or cooling of water and for outdoor use only. A different application, not expressly authorised by the manufacturer, is considered improper and therefore not permitted. The fluid to be used is exclusively water or a mixture of water and glycol (in a concentration not exceeding 10%) in the case of low water temperatures.



**It is absolutely NOT permitted to connect the flow of heated water from the machine directly to the taps of the sanitary circuit. This fluid is not intended for sanitary use and must not be ingested.**

- The location, hydraulic and electrical installation must be determined by the system designer and must take into consideration technical requirements, current local legislation and specific authorisations.



**All work must be carried out by experienced and qualified personnel, competent on the existing regulations in country where the installation takes place, as defined in EN 378-4. Personnel must also be aware of the physical properties and special hazards involved in handling R290 refrigerant gas, as well as the necessary equipment and protective devices. Each operator must have the qualification levels and overall competence defined in EN ISO 13313.**

- This device is intended for use by experienced or trained users in shops, light industry and farms, or for commercial use by non-experts.
- The appliance may be used by children at least 8 years old and by persons with reduced physical, sensory or mental capabilities or without experience or the necessary knowledge as long as they are supervised or after they themselves have received instructions on the safe use of the appliance and understand the relevant dangers. Children must not play with the appliance. The cleaning and maintenance which the user is expected to carry out on the unit cannot be done by children without supervision.
- Direct interaction with the unit by persons with electrically controlled medical devices, such as pacemakers, is prohibited, as harmful interference may result. It is recommended that an adequate distance be maintained from the installation site of the unit, as indicated by the medical system used.



**Users of electrically controlled medical devices should exercise caution when interacting with the unit.**



**Users of metallic prostheses should exercise caution when interacting with the unit.**

### 4. GENERAL SAFETY REGULATIONS

Before starting any type of operation on the SHP290 units, the operator must have read the information contained in the manual in order to be familiar with the operation of the machine and its controls.



**WARNING: The machine operates with R290 refrigerant, which is a class A3 flammable refrigerant (according to ASHRAE 34 classification). In the event of a leak, the escape of refrigerant gas into the environment can lead to the formation of a flammable atmosphere. Do not smoke and do not use open flames or fires in the vicinity of the machine (see chapters 5.4 and 5.5 for specific warnings).**

**DANGER: Risk of death or serious personal injury, observe the fire and explosion hazard information described in the manual.**

**WARNING: Any routine or extraordinary maintenance operation must be carried out with the machine stopped and disconnected. Always check that there is no voltage: there is a risk of death by electrocution if you come into contact with live electrical parts.**

**For installations in rooms that can reach outside temperatures below 0 °C, freezing of some components may occur if the unit is not in operation. Ensure that the heating system remains in operation at all times and that all rooms are sufficiently heated if there is a risk of frost. If operation cannot be guaranteed, have the heating system drained by a qualified technician.**

**Do not insert your hands, screwdrivers, spanners or any other tools on moving parts.**







**The machine operator and maintenance personnel must receive suitable training for the performance of their tasks in safety.**

**Operators must know how to use personal protective equipment and the accident-prevention rules of national and international laws and regulations.**



## 4.1 WORKERS' HEALTH AND SAFETY

The European Union has issued some directives concerning the safety and health of workers, including: 89/391/EEC, 89/686/EEC, 2009/104/EC, 86/188/EEC and 77/576/EEC and subsequent amendments which every employer is obliged to follow and have followed. We observe therefore that:

	<b>It is forbidden to tamper with or replace parts of the machine without the express authorisation of the manufacturer. This intervention releases the manufacturer from any civil or criminal liability.</b>
	<b>The unit contains flammable refrigerant gas R290. Any refrigerant leakage can generate a flammable atmosphere. Always carry out a careful fire and explosion risk evaluation.</b>
	<b>Using components, consumables or spare parts that do not correspond to those recommended by the manufacturer and/or listed in this manual may be dangerous for the operators and/or damage the unit.</b>
	<b>Keep the operating place clean, tidy and free of objects that may limit free movement. It must be properly lighted. Insufficient or excessive lighting may cause risks.</b>
	<b>Ensure that adequate ventilation of the working areas is always guaranteed and that the suction systems are always operational, in good condition and in compliance with the laws in force.</b>
	<b>In the design phase, the indications contained in UNI EN ISO 14738 regarding workstations on the machinery were followed and the lifting limits imposed by UNI ISO 11228-1 were evaluated. Make sure to maintain, during the installation and maintenance of the unit, a posture that does not cause fatigue. Check the weight, before moving any component.</b>

The unit works with R290 refrigerant, which is a refrigerant gas with a low greenhouse effect (GWP 3). It is a hydrocarbon with a low environmental impact and is not included in the list of fluorinated substances that comply with the requirements of EU Regulation No. 517/2014 called 'F-GAS' (mandatory in the European area).

The gaseous form of R290 refrigerant is heavier than air and if released into the environment, most of it tends to concentrate in poorly ventilated areas. Inhaling it can cause dizziness and sensations of suffocation and can develop lethal gas if in contact with naked flames or hot objects (see the refrigerant's safety data sheet to chapter 4.5).



Pay attention to the fact that refrigerant R290 can be odourless.

For any operation on the heat pump system:





	<b>Wear the appropriate PPE (specifically gloves and goggles).</b>
	<b>Ensure that the operating area is well ventilated. Do not work in closed ambients or ditches with insufficient air circulation.</b>
	<b>Do not operate on the refrigerant in the vicinity of hot parts or naked flames.</b>
	<b>Check that there is no voltage and ensure that the unit cannot be reconnected to the power supply during operation.</b>
	<b>Avoid any leakage of refrigerant into the environment and pay particular attention to accidental leaks from pipes and/or fittings even after the system is emptied.</b>
	<b>Make sure that there is a fire extinguisher near the unit.</b>

## 4.2 PERSONAL PROTECTIVE EQUIPMENT

Use the following personal protective equipment when operating and maintaining SHP290 units:

	<b>Clothing: Maintenance technicians and operators must wear protective clothing that does not leave parts of the body uncovered, as during maintenance it is possible to come into contact with hot or sharp surfaces. Avoid clothes that can get caught or sucked into airflows. Use antistatic clothing (ESD).</b>
	<b>Wear safety shoes with non-slip soles, especially in ambient with slippery floor. Use antistatic footwear (ESD).</b>









	Gloves: Protective gloves must be used during cleaning and maintenance. Wear antistatic gloves (ESD).
	Explosimeter for R290 gas: During maintenance operations, each operator must equip himself with an explosimeter for R290 refrigerant gas to check for its possible presence in the air. The explosimeter must not be a possible source of ignition and its sensitivity must be such that it signals an alarm when a concentration of 20% of the lower flammability limit (LFL) is reached. Do not carry electronic devices (e.g. mobile phones, computers, etc.) in the vicinity of the product before evaluating the possible presence of refrigerant in the environment.
	Mask and goggles: During cleaning operations, is necessary wear a respiratory protection (mask) and a eye protection (goggles).
	

Personal protective equipment must be checked periodically and comply with the refrigerant gas R290.





### 4.3 SAFETY SIGNS

Personnel must necessarily observe the following safety signs on the unit:

	Generic hazard.
	Dangerous electric voltage.
	Moving parts.
	Surfaces which can cause injuries.
	Boiling surfaces which can cause burns.
	Fire hazard.

### 4.4 WARNING LABELS

Warning labels with essential product safety information are applied in the external panels and in the internal parts of the units. The main symbols on the labels are the following:

	Flammable substance symbol (ISO 7010-W021).
	Read the warnings and technical instructions in the manual (ISO 7000-1659).
	Prohibition of open flames (ISO 7010-P003).
	Prohibition of smoking (ISO 7010-P002).

Note that the essential warning and safety symbols are also shown on the packaging of each unit.



<b>Name:</b>	R290
<b>HAZARDS IDENTIFICATION</b>	
<b>Main hazards:</b>	Highly flammable gas. Vapours are heavier than air and can cause asphyxiation due to reduced oxygen levels.
<b>Specific hazards:</b>	Contact with the liquid can cause frost burns.
<b>FIRST AID MEASURES</b>	
<b>General information:</b>	In high concentrations it can cause asphyxia. Symptoms may include loss of mobility and/or consciousness. In low concentrations it may have a narcotic effect.
<b>Inhalation:</b>	Move the victim to an uncontaminated area while wearing self-contained breathing apparatus. Use oxygen or artificial respiration artificial respiration if necessary. Keep the patient lying down and warm. Call a doctor.
<b>Eye contact:</b>	Carefully rinse with plenty of water for at least 15 minutes.
<b>Skin contact:</b>	Wash immediately with plenty of water for at least 15 minutes. Immediately remove contaminated clothing.
<b>FIRE FIGHTING MEASURES</b>	
<b>Extinguishing media:</b>	Water spray, dry powder.
<b>Specific hazards:</b>	Exposure to flames may cause the vessel to rupture or explode.
<b>Specific methods:</b>	Cool down the containers with a water spray from a safe position. Stop the product leakage if possible. Use water spray, if possible, to abate the fumes. Move the vessels away from the area of the fire if this can be done without posing any risks.
<b>ACCIDENTAL RELEASE MEASURES</b>	
<b>Personal precautions:</b>	Try to stop the leak. Evacuate personnel to safety areas. Eliminate the ignition sources. Ensure proper ventilation. Avoid entering sewers, basements, excavations and areas where accumulation can be dangerous. Use personal protective equipment. Remain upwind.
<b>Environmental precautions:</b>	Try to stop the leak.
<b>Cleaning methods:</b>	Ventilate the area.
<b>HANDLING AND STORAGE</b>	
<b>Handling: Technical measures/precautions:</b>	Ensure sufficient air exchange and/or suction in the working area. Do not smoke. Keep away from sources of ignition (including electrostatic charges). Use only appropriate equipment, suitable for the product.
<b>Advice for safe use:</b>	Do not inhale the gas.
<b>Storage:</b>	Close carefully and store in a cool, dry and well ventilated area. Storage containers should be checked periodically. Do not store with other oxidants in general or other combustible substances. All electrical equipment in the storage area are compliant with the risk of explosive atmospheres formation.
<b>EXPOSURE CONTROLS/PERSONAL PROTECTION</b>	
<b>Control parameters:</b>	OEL: data not available. DNEL: data not available. PNEC: data not available.
<b>Respiratory protection:</b>	Filter masks can be used if the ambient conditions and duration of use are known.
<b>Eye protection:</b>	Safety goggles.
<b>Hand protection:</b>	Work gloves.
<b>Hygienic measures:</b>	No smoking.
<b>PHYSICAL AND CHEMICAL PROPERTIES</b>	
<b>Colour:</b>	Colourless.
<b>Odour:</b>	Odourless.
<b>Boiling point:</b>	-42,1 °C at atm press
<b>Flash point:</b>	470°C
<b>Relative gas density (air=1)</b>	1,50
<b>Relative liquid density (water=1)</b>	0,58
<b>Solubility in water:</b>	75 mg/l.
<b>STABILITY AND REACTIVITY</b>	
<b>Stability:</b>	Stable under normal conditions.
<b>Materials to avoid: Decomposition products hazardous:</b>	Air, oxidising agents . Keep away from heat sources/sparks/open flames/heated surfaces. Under normal conditions of storage and use, dangerous decomposition products should not be generated.
<b>TOXICOLOGICAL INFORMATION</b>	
<b>Acute toxicity:</b>	CL50/inhalation/4 hours/on rat = 20000 ppm.
<b>Local effects:</b>	No known effect.
<b>Long term toxicity:</b>	No known effect.
<b>ENVIRONMENTAL INFORMATION</b>	
<b>Global warming potential GWP (R744=1):</b>	3
<b>Ozone Depletion Potential ODP (R11=1):</b>	0
<b>Disposal consideration:</b>	Refer to the supplier's gas recovery programme. Avoid direct discharge into the atmosphere. Do not discharge where accumulation can be dangerous. Ensure that the emissions limits required by local regulations or specified in authorizations are not exceeded.



## 4.6 SPECIFIC R290 GAS WARNINGS

The R290 refrigerant gas:

- is odourless;
- is highly flammable (Class A3refrigerant), only if a ignition is present;
- it may cause an explosion, but only if a given concentration in air is reached.

It is good practice to follow these guidelines:

- do not smoke near the unit;
- affix a no smoking sign near the unit;
- do not inhale the gas;
- install the unit in outdoor area respecting the required technical spaces and danger zones indicated in this manual;
- do not drill or burn the unit;
- do not place the unit near sources of ignition, such as open flames, electric heaters, switches for lights, sockets, lamps or other permanent ignition sources;
- any extraordinary maintenance or repair on the unit must be performed by technicians or qualified personnel, properly trained with specific skills in handling flammable refrigerant gases, comply with local laws;
- after installation of the machine and before carrying out any maintenance work, ensure, by means of a leak detection test, that no concentration of R290 gas can be measured in the danger zone.

## 4.7 INDICATIONS FOR VACUUM AND CHARGE WITH R290 GAS

Vacuum, charging and refrigerant gas recovery procedures may only be carried out by technicians or qualified personnel, who are adequately trained in the handling of flammable gases and comply with local laws. Follow the requirements below:

- Ensure that other types of refrigerant do not contaminate the R290 (the minimum purity of the refrigerant gas used for charging operations must be at least 99,5%);
- For refrigerant gas recovery, use cylinders with a left-hand connection and appropriate pitch. The maximum filling capacity must be 0,42 kg/L;
- Before charging the refrigerant gas, carry out three flushing cycles with pressurised nitrogen followed by a proper vacuum procedure;
- Keep the gas cylinder in a vertical position when filling;
- Apply the label on the appliance after loading;
- Wear work equipment suitable for operate with flammable gas (see Chapter 5.9 for more information). Always keep the work area well ventilated and equip yourself with detection devices for R290;
- Do not charge more refrigerant gas than necessary. It should be noted that the performance of i-290 units is very sensitive to the amount of gas loaded, so a charging error can lead to malfunctions or even machine stoppages. It is recommended to charge the unit using calibrated scales with a reading sensitivity of at least a tenth of a gram;
- Once loading is complete, perform leak detection operations prior to function test;
- Perform a second leak check, once all the previous operations have been completed.



**ATTENTION:** Each unit is equipped with two charging connections (high-pressure side and low-pressure side) to ensure charging and discharging of the refrigerant circuit. The maximum tightening torque of the charging connections is 0.5 Nm.



**ATTENTION:** The unit is already charged with the refrigerant gas necessary for its correct operation. If it is necessary to recharge it, after a maintenance operation or after a leak, follow the procedures described in Chapter 5.9.



**ATTENTION:** During the charging and recovery procedure of the unit, beware of possible refrigerant gas leaks that could start a fire. Always carry out a risk assessment and apply the necessary preventive actions.

## 4.8 R290 GAS DISPOSAL

The procedures described below may only be performed by skilled technicians or qualified personnel, adequately trained and with specific skills that comply with local laws:

- Do not discharge the gas in area where there is a risk of explosive mixtures forming with air. The gas should be disposed of in a suitable torch with a flashback arrestor. Follow current regulations regarding the disposal of refrigerant gases. Contact the supplier if operating instructions are considered necessary;
- Only use equipment approved for use with R290 refrigerant;
- When removing and disposing of the refrigerant, ensure that no air enters where the refrigerant is present (refrigerant circuit, cylinders or other containers for transporting the refrigerant).



**ATTENTION:** During the refrigerant disposal procedure, beware of possible gas leaks that could start a fire.

## 4.9 SAFETY RULES FOR R290 UNITS TRANSPORT AND STORAGE

Before opening the unit's packaging, ensure there are no gas leaks in the environment with an appropriate gas detector. Check that there are no ignition sources near the unit.



No smoking near the unit.

Transport and storage must be performed in accordance with the national regulations in force. Specifically, according to ADR provisions, the total maximum quantity by transport unit in terms of net mass for flammable gases is 333 kg. In addition, for road transport, use vehicles that are preferably open or equipped with a ventilation system and operated by trained personnel.

For prerequisites on the transport by sea of equipment loaded with flammable refrigerant refer to the International Maritime Dangerous Goods Code (IMDG), and for transport by air check the regulations prescribed by the International Air Transport Organisation (IATA).

Please observe the following precautions:

- if storage is in a closed location, leave the machine in a dedicated place that is always dry, cool, well ventilated and protected from possible ignition sources, direct sunlight or other heat sources. It is also recommended to use one flammable gas detection sensor per 36-40 m<sup>2</sup>. Always refer to national regulations;
- if storage is carried out in an open area, observe the minimum safety distances from drains, cisterns, sewers and other underground areas, in accordance with the national regulations in force;
- do not remove covers and packaging;
- ensure that all panels are correctly mounted;
- do not obstruct the openings and holes made in the machine panels;
- avoid cleaning the unit with aggressive detergents or chemicals;
- it is advisable to remove any heating water inside the unit to prevent possible corrosion or, in cold climates, damage to components caused by freezing.



**CAUTION:** When transporting and storing the unit, beware of possible refrigerant gas leaks that could start a fire.

## 5. INSTALLATION



**CAUTION:** All the operation described below must be done by **QUALIFIED PERSONNEL ONLY (EN 378-4)**. Before any operation on the unit, make sure that power supply is disconnected. When transporting and storing the unit, beware of possible refrigerant gas leaks that could start a fire.

### 5.1 GENERAL

When installing or working on the refrigeration circuit, it is necessary to scrupulously comply with the regulations in this manual, observe the instructions on the unit and in any case apply all necessary precautions. Failure to comply with the instructions may lead to dangerous situations.



After receiving the unit, immediately check its integrity. The unit left the factory in perfect condition; any damage must be immediately reported to the carrier and recorded on the Delivery Note before signing it.

The company must be informed, within 8 days, of the extent of the damage. The customer should prepare a written statement of any severe damage.



The units are designed to be installed outdoors. Under no circumstances should the outdoor ambient temperature exceed 46°C when the unit is not in operation. Above this value, the unit is no longer covered by current pressure equipment safety regulations.



The installation place must be without any fire risks. All necessary measures must therefore be taken to prevent the risk of fire at the installation site (see Chapter 5.5 for more details). The device must not be placed in the vicinity of open flames, ignition sources or heat sources.

The wall of the buildings near the unit must have an adequate fire resistance class, in order to contain any fire that may develop inside the rooms. However, it is recommended to place a fire extinguisher near the unit.



The unit must be installed in order to allow maintenance and repair. The warranty does not cover costs for platforms or other lifting equipment needed for any interventions.



The unit must be installed away from and not connected to any lightning towers or other objects/constructions that can attract the discharge.



All the maintenance operations and tests must be done by **QUALIFIED PERSONNEL (EN 378-4)**. All equipment used during maintenance operations must be compatible with the refrigerant gas R290.



Before any operation on the unit, make sure that the power supply is disconnected and cannot be switched on again accidentally. After disconnecting the power supply from the unit, wait at least 5 minutes before performing any operation on the machine to allow the condenser to discharge.



	Do not use equipment to speed up the defrost process or for cleaning except for those recommended by the manufacturer.
	The appliance must be placed outside, in a place without continuously operating ignition sources (e.g. open flames, an operating gas appliance or an operating electric heater). Refer to Chapter 5.5.
	Do not perforate or burn. Do not make mechanical modifications to the unit.
	There are some moving parts inside the unit. Use extreme caution when working near them, even if the power supply is disconnected. In particular, pay attention to the fan blades when removing the front protective grilles. Do not touch or insert any objects into the moving parts.
	The compressor heads and discharge pipework are at quite high temperatures. The pipes on the suction side of the compressor, on the other hand, can reach very low temperatures. Uninsulated pipes can cause burns or freezer burns: only handle these components when their temperature is close to ambient.
	Be particularly careful when working near batteries. Aluminium fins are very sharp and can cause serious injury.
	After the maintenance operations, close the panels by fixing them with screws.
	Cable ducts and electrical conduits to the machine must not contain potential ignition sources.
	After maintenance or replacement of components, reconnect the cables in the same position as in the factory.
	Routine maintenance operations can be carried out with the machine charged, while in the case of extraordinary operations, repairs or replacement of components and heavy work in the vicinity of the machine (e.g. construction sites), drain the machine of coolant gas and move it to a safe area if necessary (in accordance with Chapter 5.5).
	Insulating materials are not self-extinguishing: remove them when working on the unit, if necessary.
	Do not remove, replace or make illegible the adhesive labels on the unit and packaging. Do not cover the labels after installation of the unit.

## 5.2 TRANSPORT AND STORAGE TEMPERATURE LIMITS

Minimum storage temperature [°C]	-10 °C
Maximum storage temperature [°C]	+50 °C

## 5.3 LIFTING AND HANDLING

The handling must be performed by qualified personnel, properly equipped with appropriate tools to the weight and the encumbrance of the unit, in compliance with safety regulations of accident preventing. It is recommended:

1. check the weight on unit technical label or on table of technical data;
2. check moving the unit there are no disconnected paths, ramps, steps, doors that could affect the movement and damage the unit;
3. check that the unit remains horizontal when moving;
4. during handling, do not carry out abrupt and sudden manoeuvres in order to not destabilise the unit;
5. before handling the unit, check that the equipment is suitable for lifting and preserving the integrity of the unit;
6. check the centre of gravity of the unit and align it with the lifting point;
7. perform lifting only by one of the listed procedures;
8. before starting handling make sure, the unit is in stable equilibrium.



Note that the weight of the unit is concentrated more on the side of the refrigeration circuit: take into consideration the weight distribution of the machine when transporting it manually with ropes, in order not to lift excessive loads and avoid damage or personal injury. It is recommended to remove the packaging only after the machine has been placed in the actual installation location. Dispose of the different packaging materials in accordance with national regulations.



Before commissioning, carefully inspect the unit and packaging for damage or refrigerant leakage.



Do not proceed with the start-up of the unit if damage was found during transport. Immediately inform the Company of the problem. The company is not liable for any damage to the product caused by handling and transporting the unit in a manner not in accordance with this manual and the regulations in force.

## 5.3.1 Lifting mode

Carry out lifting operations only by one of the methods listed below:

- forklift truck;
- thick lifting tubes according to EN 355 and EN 10297-1, to be inserted into the appropriate holes in the base + ropes/chains;
- lifting brackets (available as an accessory) + ropes/chains + sling bar. Be sure to tension the lifting ropes gradually and check that they are correctly positioned.

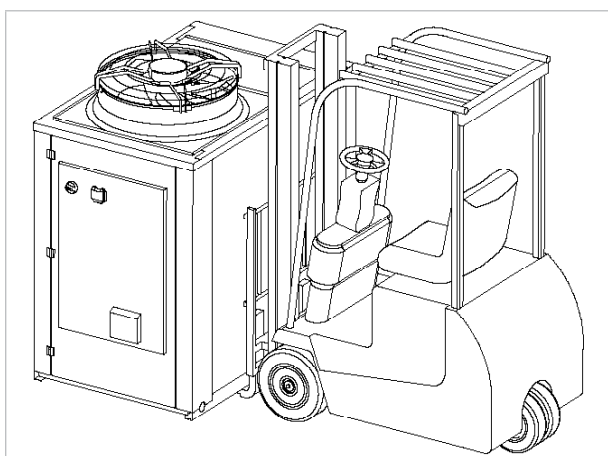

Lifting through forklift truck.

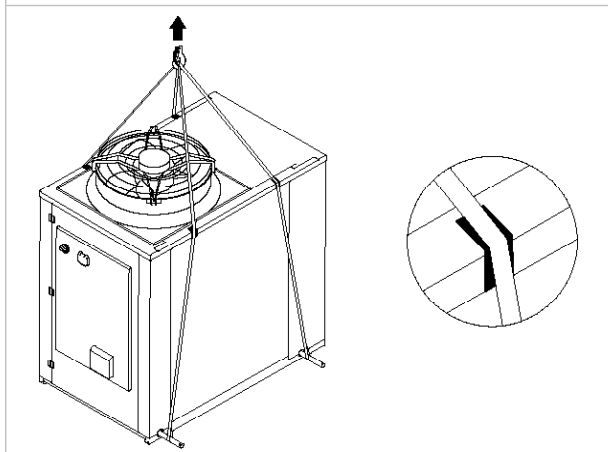

Lifting with ropes / bands.

## 5.3.2 Damage to the unit

In the event that the product is damaged during handling, storage or transport (e.g. due to dropping), follow the procedure described below:

1. take the damaged unit outside.
2. enclose a zone of at least 3 m around the unit, within which there must be no manholes, culverts, depressions or other connections to underground areas.
3. ensure that there is no source of ignition from the newly defined work area.
4. check for possible refrigerant leaks using a leak detector.
5. if necessary, remove the product packaging.
6. drain the refrigerant gas as described in chapter 5.9.

For further clarification, contact a technical service centre.









## 5.4 POSITIONING AND MINIMUM TECHNICAL CLEARANCES

All models of SHP290 are designed and constructed for outdoor installations. The company is not liable for any damage to property, animals and/or persons resulting from failure to comply with the instructions on installing the unit described in this manual.



It is advisable to create an adequately sized support base for the unit. The units transmit a small amount of vibrations to the ground: however, it is advisable to place anti-vibration mounts between the base frame and the supporting surface. It is preferable to install the unit away from places sensitive to noise and vibration (e.g. windows and glass panes).

Always make an environmental impact assessment based on the power and sound pressure data in chapter "12. TECHNICAL DATA" and the sound emission limits according to the installation area of the unit, with reference to the DPCM of 14/11/1997. An assessment must also be made if the unit is installed near workers, according to D. LGS. 81/2008 Art. 189 and following.

	In case of hanging installation, it is necessary to make sure that the wall has been made with solid bricks, concrete or similar. The wall capacity needs to be enough to support at least four times the weight of the unit. The maximum installation height is 800 mm.
	The support plane must have enough capacity to support the unit weight, which can be checked both on the technical label on the unit and on this technical manual under chapter 12. The support plane must not be inclined to ensure the unit works properly and avoid a possible overturning. The support plane must not be smooth, to avoid water/ice deposit as potential sources of danger.
	Unit installation place must be free from foliage, dust, etc., which could clog or cover the coil. Installation in areas subject to water stagnation or fall, for example from gutters, should be avoided. Also, avoid areas subject to snow accumulation (such as corners of buildings with sloping roofs). In case of installation in areas subject to snowfall, it is advisable to place the unit on a base raised from the ground by 20-30 cm, to prevent the formation of snow accumulations around the machine, which can obstruct the battery and the perforations on the side panels and base of the machine. Also avoid positioning near lightning towers or other objects that can attract an electric shock.
	It is recommended that sufficient air exchange be ensured to dilute R290 gas in the event of its accidental escape, thus preventing the formation of explosive atmospheres. For this reason, a minimum distance (depending on the unit) must be maintained from any openings or manholes, in which the gas could accumulate. Respect national regulations for the installation of the machine.
	The units are suitable for installation in urban, industrial, coastal and rural areas. If the unit is installed in an environment with aggressive atmospheres, the air sucked in by the fan may contain substances that can cause damage to the panels, grilles and internal components of the unit. In this case, the operating life of the unit will be limited.
	It is prohibited to install the unit under roofs of any kind, such as roofs, canopies and similar, placed at a height of less than 1.5 m from the unit cover.
	It is prohibited to install the unit in a location below ground level (such as cellars, underground car parks, basement or underground work rooms, etc.).
	If the unit is installed in a restricted occupancy zone (class "b" or "c" areas according to EN 378-1), suitable arrangements must be made so that only authorised personnel have access.
	The installation site must be chosen in compliance with the refrigerant charge limits of EN 378-1 Annex C.

It is very important to avoid recirculation between intake and delivery air, so as not to downgrade performance of the unit or even to interrupt its normal operation. This is why the minimum clearances shown below must be strictly guaranteed.

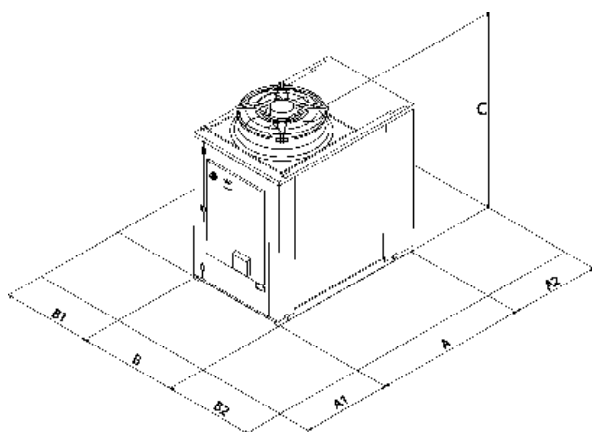

SHP290		A1	A2	B1	B2
SHP290 40 kW / 50 kW	mm	1200	1000	1500	1500



For strong wind installation place refer to the classification of the area according to the Beaufort table. If the value is  $> 7$  (strong wind, average wind speed = 13, 9-17, 1 m/s) it is strictly necessary to keep the fan always powered, thus preventing involuntary rotation of the same.



If the unit is installed at a distance of less than 1 km from coastal and maritime areas, the presence of salt and sand in the air greatly increases the likelihood of corrosion. Install the unit so that it is protected from direct sea wind if necessary, provide windbreaks on site (observing the minimum distances indicated).

In the event of side-by-side units, the minimum  $L_{min}$  distance between them is 2,2 m.

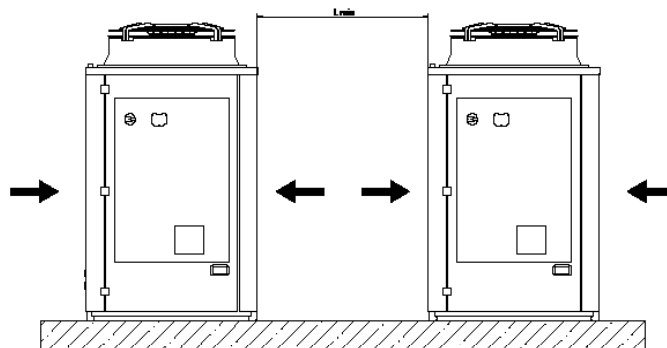

Covering with canopies or placing near plants or walls should be avoided to prevent air recirculation.

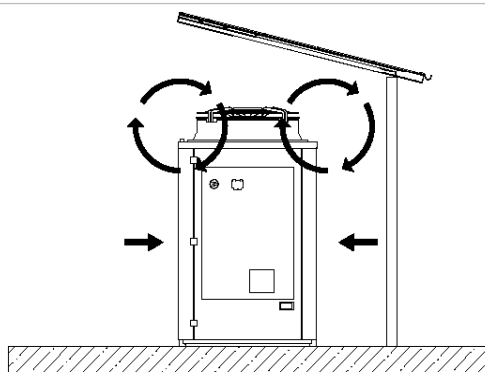

In the event of winds stronger than 13,9-17,1 m/s (strong winds according to the Beaufort scale) the use of wind barriers is recommended.

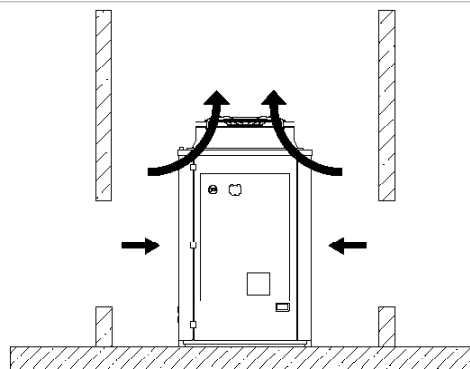

## 5.5 DANGER AND SAFETY ZONES

The SHP290 series units contain R290 refrigerant gas. The density of this gas is greater than that of air, so in the event of leakage it tends to disperse and stratify, accumulating in niches, depressions in the ground or underground regions.

It is mandatory to comply with the danger and safety zones given in this manual, when installing the units. These zones have been designed in accordance with EN 60079-10-1, using the refrigerant loss rate given in EN 378-2 Annex I, in order to guarantee the safety of the units in the installation area. A danger zone is defined as a area around the machine in which, in the event of a leakage of refrigerant gas, a flammable atmosphere is formed for a short time, within which it is necessary to implement all the precautions described in the manual. In the absence of specific standards or regulations, when using the unit in an industrial or working environment, it is advisable to carry out the classification of places with explosion hazards considering the ATEX Directive 1999/92 (Directive 89/391). There must NOT be any sources of ignition in the danger zones, including:

- flammable gases and sprays, self-igniting powders;
- electrical equipment that is not suitable for use in potentially explosive areas (zone 2 according to Directive 89/391);
- naked flames, heated surfaces (maximum surface temperature of 360°C) and processing by heat; smoking is prohibited, even for electronic cigarettes;
- sparks, electrostatic charges, direct and indirect lightning effects, eddy currents and cathodic protection;
- ignition sources due to remote processes (ionising and non-ionising radiation);
- permanent electrical sources (switches, lamps, etc.) or other possible triggers;

In addition, danger zone must NOT:

- include potentially dangerous areas or elements such as wells, manholes, openings to the sewage system and other openings to underground places and premises (e.g. garages), river drains, power lines, flammable deposits, electrical installations, etc.;



- include doors, windows or glass panes, to prevent the possible return of the gas inside the building;
- extend towards neighbouring residential properties, parking areas, public access sites, roads or railways.

A safety zone extending beyond the danger zone must also be identified. Within the safety zone, in the event of a refrigerant leak, the concentration of the gas in the air is typically below the critical levels for the formation of flammable or hazardous atmospheres. Compliance with the following provisions remains mandatory:

- prevent accumulation and stagnation in underground spaces, drains, manholes, cellars, etc.;
- do not place building vents inside or near the safety zone;
- do not use naked flames and other direct heat sources.

In any case, comply with national and local regulations for the installation of machinery (as applicable) in order to prevent the formation of fire hazards and to prevent gases from seeping underground into openings to the ground or floors below.

No structural modifications may be made in the danger and safety zones that would alter their extent or change the behaviour of the air-coolant mixture.

It is also strictly forbidden to tamper with, alter, remove or compromise, even partially, the functionality of the devices, guards and prescriptions provided for the safety of property and persons.

In this manual, different types of outdoor installation are considered, as indicated in the following paragraphs.

## 5.5.1 Free-field ground installation

For unit installed in open field terrain, the danger (continuous red line) and safety zones (dashed black line) are shown in the figures below:

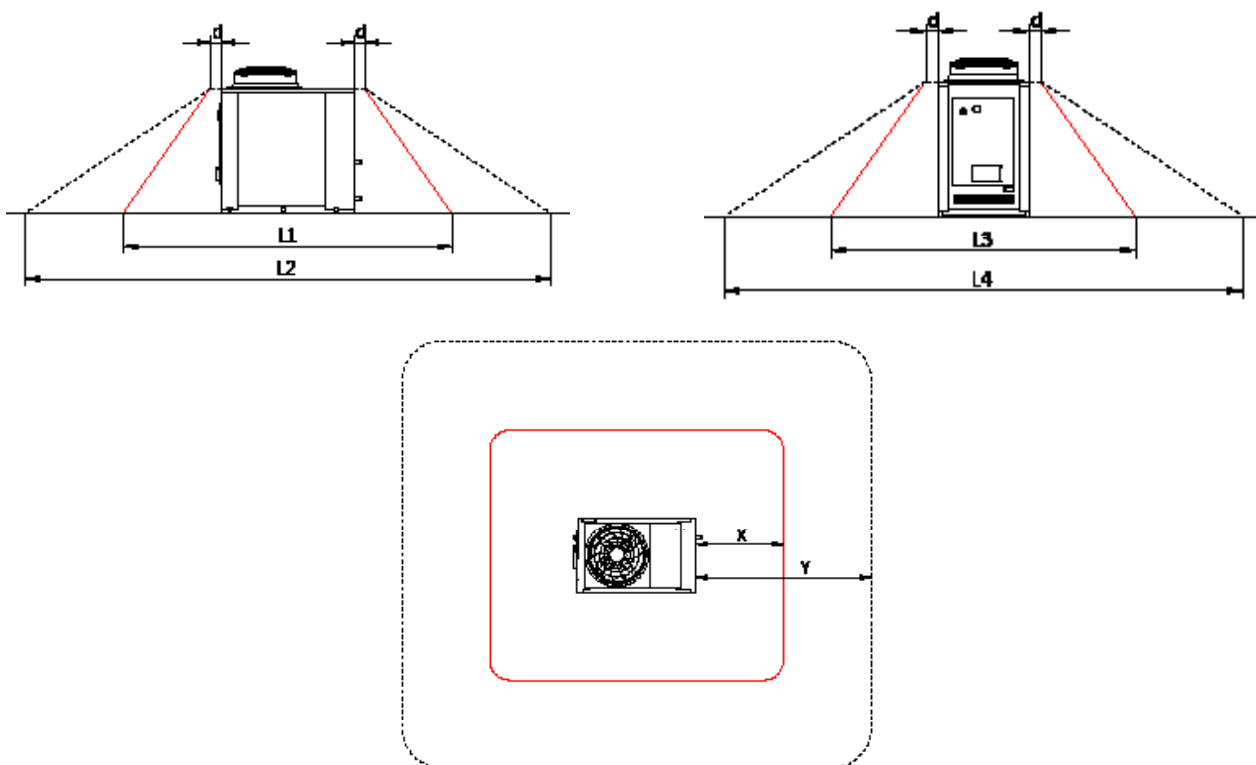

SHP290		X	Y	L1	L2	L3	L4	d
40 kW	mm	1500	3000	4850	7850	4110	7110	250
50 kW	mm	1500	3000	4850	7850	4110	7110	250

## 5.5.2 Ground installation in front of a wall

In the case of units installed on the ground in front of a wall, the danger (continuous red line) and safety zones (dashed black line) are shown in the figures below:

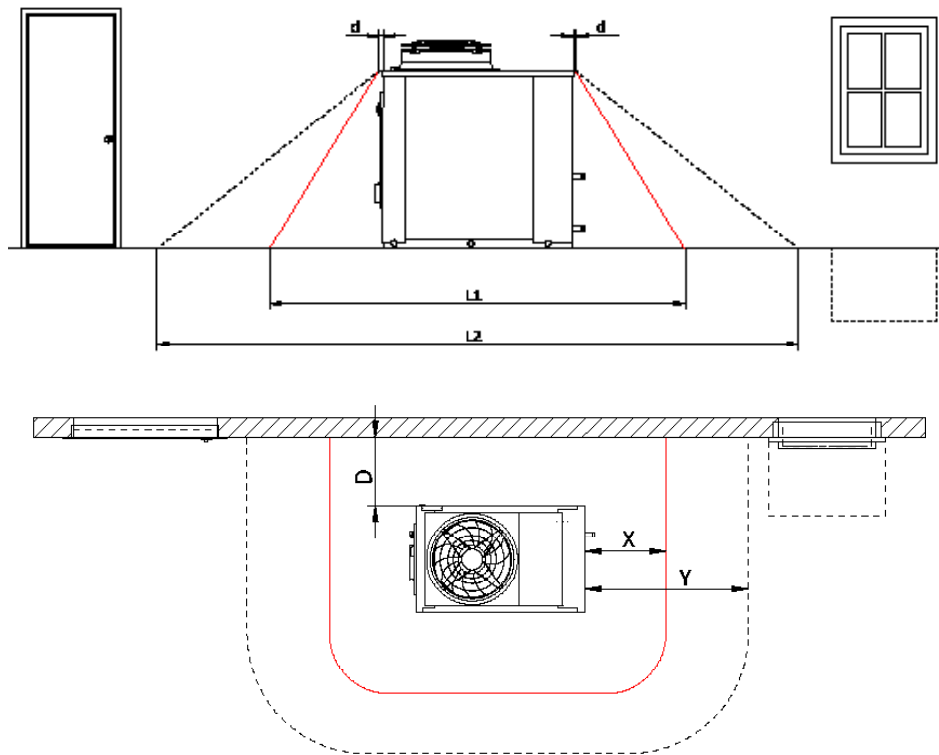

SHP290		X	Y	L1	L2	D	d
40 kW	mm	1500	3000	4850	7850	1500	250
50 kW	mm	1500	3000	4850	7850	1500	250

### 5.5.3 Ground installation in a corner

For units installed on ground in a corner, the danger (continuous red line) and safety zones (dashed black line) are shown in the figures below:

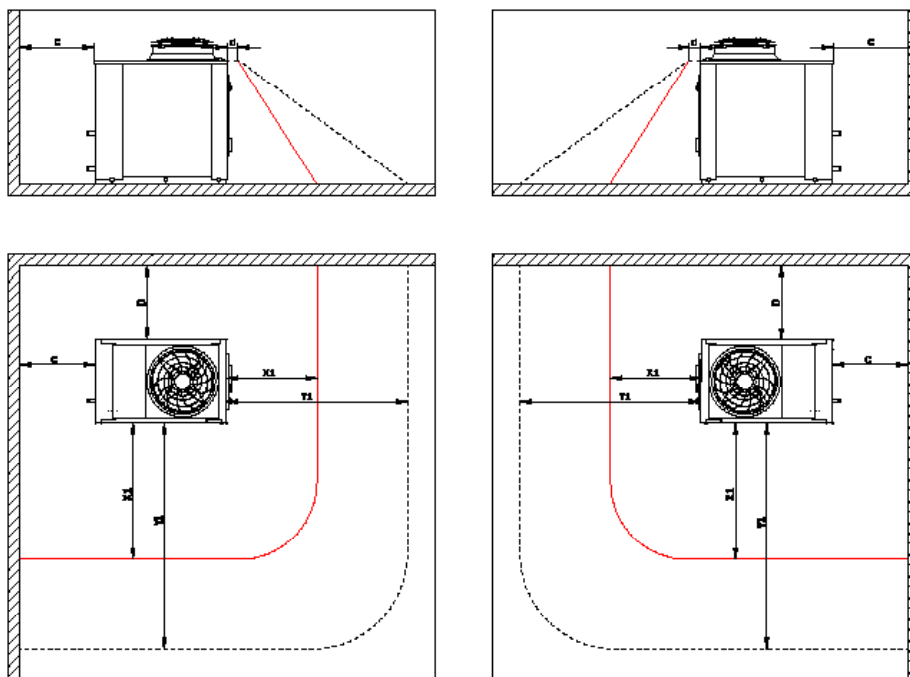



SHP290		X1	Y1	C	D	d
40 kW	mm	2750	4250	1000	1500	250
50 kW	mm	2750	4250	1000	1500	250

## 5.5.4 Flat roof installation

The installation configuration on a flat roof is similar to that on a free-field ground, although some additional aspects must be considered:

- place the machine at a sufficient distance from side walls and protrusions, which must therefore be beyond the safety zone;
- ensure that the roof structure of the building is solid;
- choose a location where no accumulations of snow, dust or foliage can form;
- pay attention to noise emissions and maintain an adequate distance from surrounding buildings;
- if high air velocities are detected, install the protections listed in the previous chapter.

## 5.5.5 Multiple installation

When installing several machines side by side, follow the above configurations, maintaining a respect distance of L between each machine. As an example, see the following respect zones (danger and safety) for the case of a generic number "n" of units installed on open field terrain:

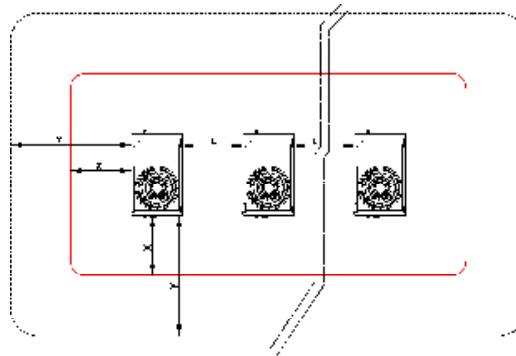

SHP290		X	Y	L
40 kW	mm	1500	3000	2200
50 kW	mm	1500	3000	2200

For other types of installation not covered in this manual, contact technical support. If in doubt about the installation of the units, request a technical assessment by the fire brigade or a fire prevention expert.



## 5.6 DIMENSIONS

### 5.6.1 Standard version

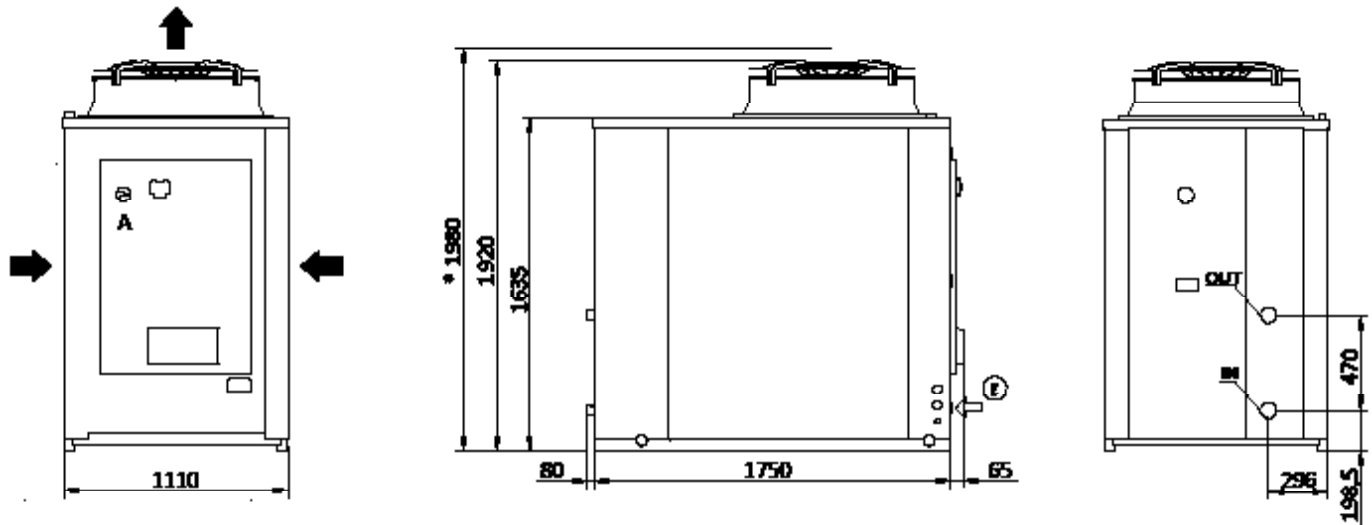

Dimensions			
A - Length	mm		1895
B - Depth	mm		1110
C - Height	mm		1920
C - Height SSL/C/C(S) version	mm		1980
IN / OUT	inch		1" 1/2 Grooved
E	-		Power supply input

### 5.6.2 Version with tank kit

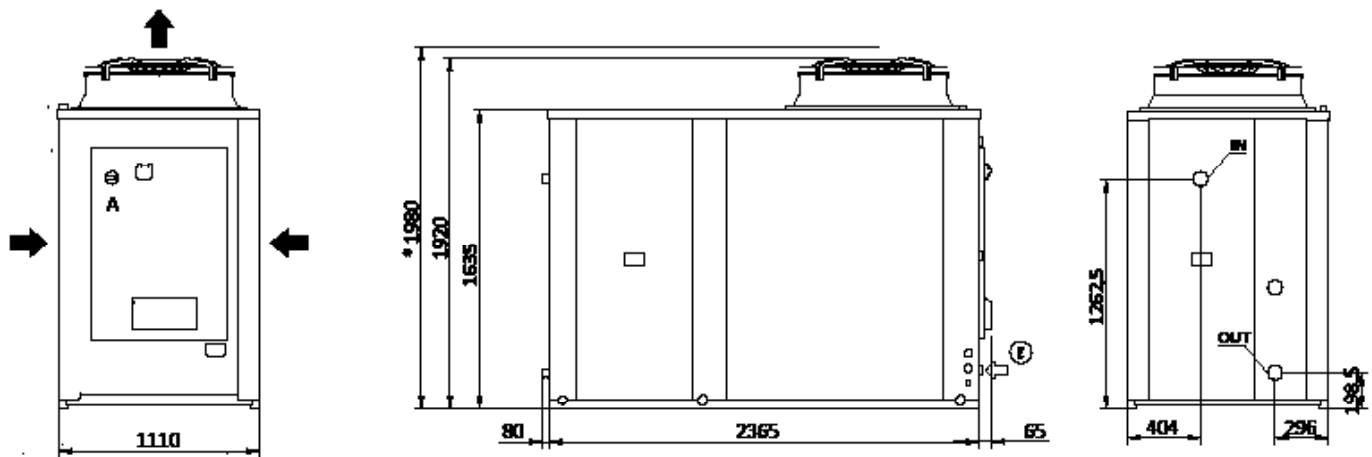

Dimensions			
A - Length	mm		2510
B - Depth	mm		1110
C - Height	mm		1920
C - Height SSL/C/C(S) version	mm		1980
IN / OUT	inch		1" 1/2 Grooved
E	-		Power supply input



## 5.7 POSITIONING OF CENTRE OF GRAVITY AND VIBRATION DAMPERS

The position of the centre of gravity of each machine is indicated in the tables, with reference to the dimensions shown in the image. A distinction is made between the standard machine version, with hydronic kit and if the tank is also installed.

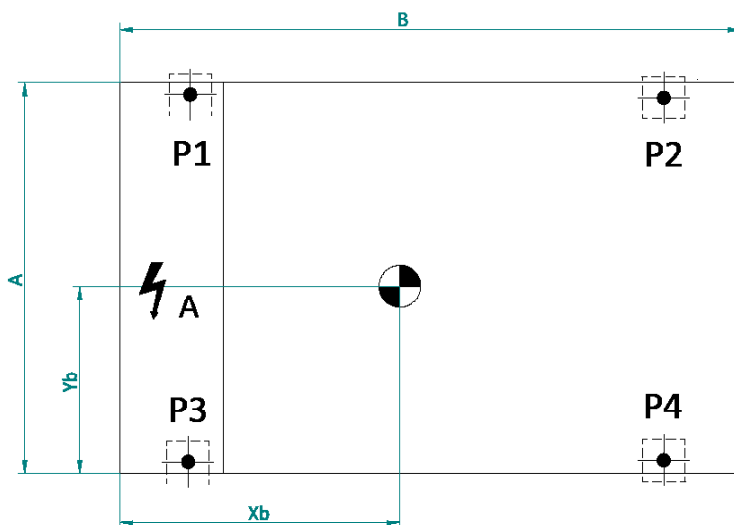

Models	Version	A [mm]	B [mm]	Xb [mm]	Yb [mm]
SHP290 40 kW	Standard	1110	1754	652	517
	With tank kit	1110	2365	970	540
SHP290 50 kW	Standard	1110	1754	665	520
	With tank kit	1110	2365	963	540

Version	Models	SHP290	SHP290
Standard	Shipping weight [kg]	510	525
	Operating weight [kg]	515	530
With pump kit	Shipping weight [kg]	535	550
	Operating weight [kg]	542	557
With pump and tank	Shipping weight [kg]	655	670
	Operating weight [kg]	1090	1105

The positions for the installation of vibration dampers for each type of machine are shown in the following pictures.

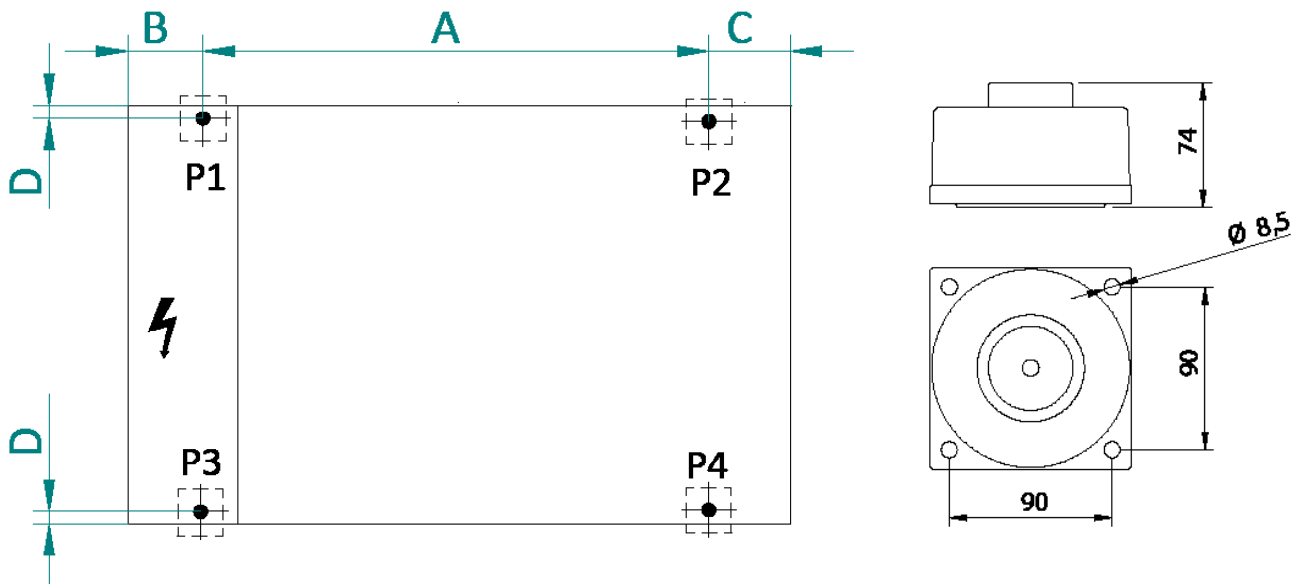

Models	Version	A [mm]	B [mm]	C [mm]	D [mm]
SHP290 40 kW / 50 kW	Standard	1410	105	235	32
	Hydronic kit with tank	2180	105	80	32

## 5.8 ACCESS TO THE INNER PART

### 5.8.1 Access to the inside of the unit on the electrical panel side

In the event of maintenance and/or inspection of the compressors, it is necessary to access the inside of the unit by opening the door, located at the front where the electrical panel is also located. To unlock it, it is necessary to unscrew the fixing screws using the appropriate tool and pull it towards you using the handle located under the panel. Pay attention to the electrical panel which is attached to the door itself. For access to the panel, see the relevant chapter.

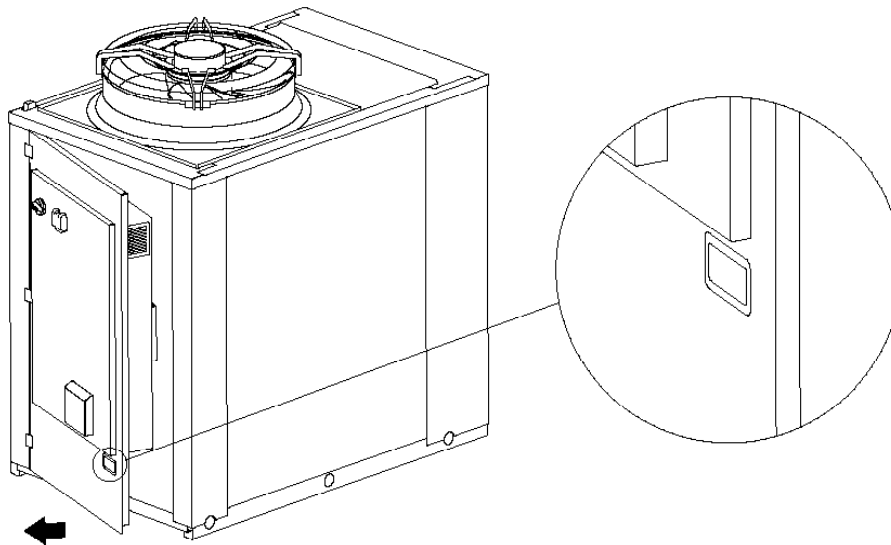

The operator must pay attention to the fins of the driver which protrude from the inside and can be sharp at the edges.



Pay particular attention to any slight unevenness that may cause the door to close unintentionally with the risk of crushing.



All access to internal parts and the electrical board must be carried out strictly with the machine switched off and disconnected from the power supply. Operations to be performed by qualified personnel.



When the work is complete, replace all the removed covers with all the screws and seals provided (if any).

## 5.8.2 Access to the inside of the unit on the hydronic kit side

For maintenance and/or inspection of the hydronic part and part of the refrigeration circuit, it is necessary to access the inside of the unit from the rear side, near the hydraulic connections. Simply unscrew the screws securing the rear panel and remove it from the housing. In the case of a tank kit, both sides of the additional appendix can also be removed.

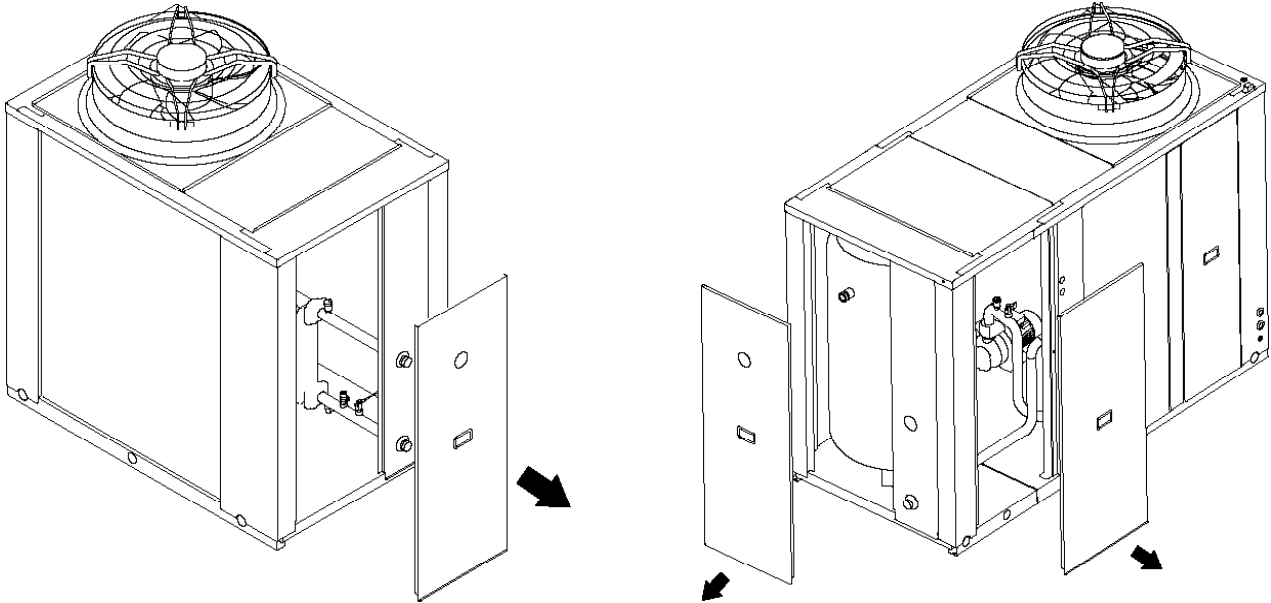

## 5.8.3 Thermostat position and temperature probe

The safety thermostats are located on the compressor discharge pipes (position D and D' in the figure). To access them, remove the component insulation. There are 6 temperature probes inside the machine: the water-side return and delivery probes (position B, C) and the compressor-side suction and delivery probes (position A, E, E'), while the outside air probe (position F) is located on a dedicated support. The probes on the compressor pipes are fixed by clips to the respective thermowells.

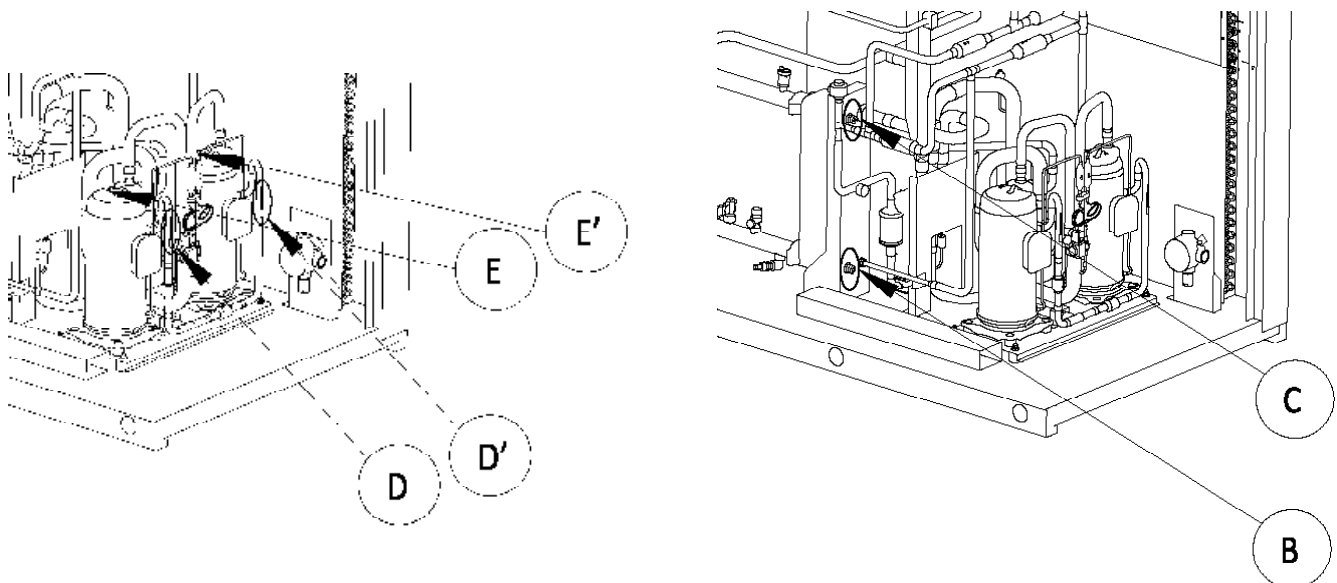

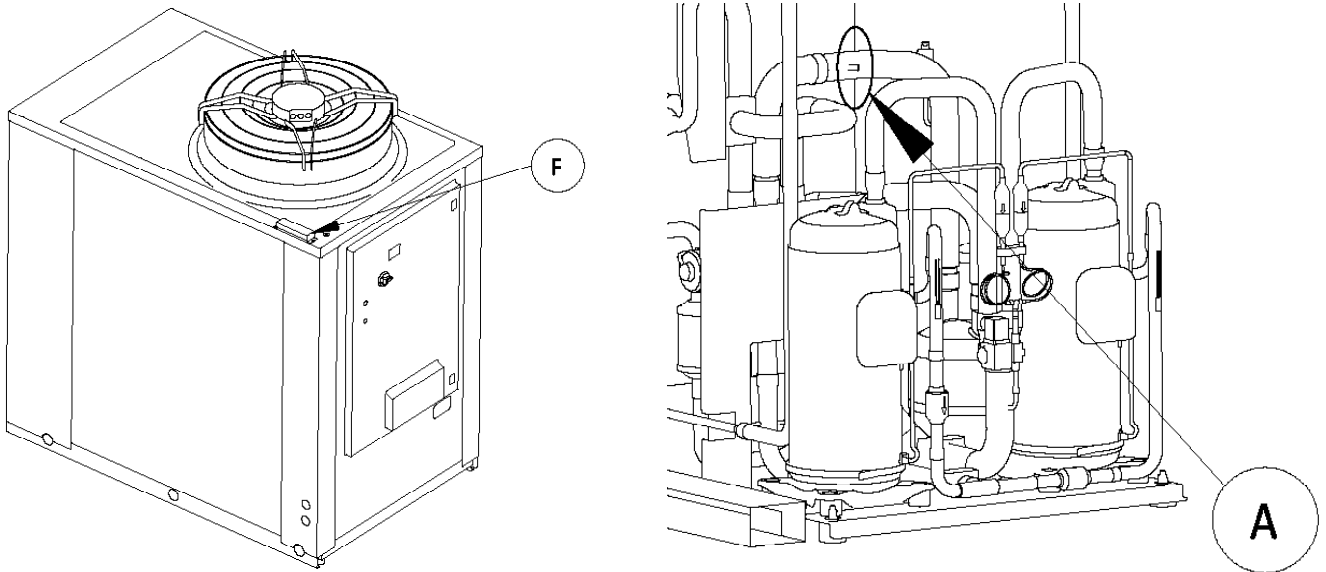

## 5.9 MACHINE CHARGING PROCEDURE

The unit is supplied already charged with refrigerant gas. If it is necessary to recharge it, after a maintenance operation or after a leak, follow the step listed below in this exact order:

- Before proceeding with any work, carry out a risk analysis and demarcate the work area. Ensure that no possible source of ignition is present in it. The minimum space should be 3 m around the unit and must not include manholes, drains or other depressions where refrigerant gas could be deposited;
- Display warning signs and prevent access by unauthorised personnel;
- Use the PPE indicated in this manual and the appropriate personal equipment for the intervention. This equipment includes:
  1. Explosimeter, to check for the presence of hydrocarbons in the environment (to be used before and while working on the system).
  2. Appropriate hoses for the type of compressor oil.
  3. Approved non-sparking equipment.
  4. Non-sparking sockets.
  5. Antistatic (ESD) footwear and clothing.
  6. ATEX torch.
  7. Fittings for minimum emissions.
  8. Pin extractor.
  9. CO<sub>2</sub> extinguisher.
- Connect to the charging socket (position A,B and C,D,E in the following picture) of the circuit with a hose and recover the refrigerant gas completely. Use a suitable recovery machine (ATEX). In order not to contaminate the recovery gas, reclaim the equipment by vacuuming the hoses and the recuperator. Frequently check the condition of seals and filters. It is recommended to remove the pin using a pin extractor to considerably reduce the vacuum and charging time of the system;

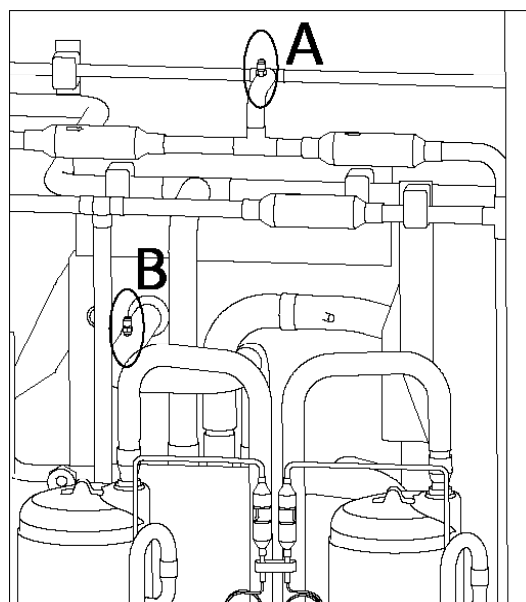



- flush the circuit by introducing nitrogen and bringing the pressure up to 4-5 bar. Expel nitrogen from the unit away from heat sources, ignition points, wells and other possible stagnation points;
- vacuum the system to an absolute pressure value of no more than 200 Pa. At this stage, use a fan (ATEX) to avoid refrigerant gas stagnation in the working area. Take care to direct the air flow to an area without sources of ignition;
- complete this wash and vacuum cycle at least three times;
- create a high vacuum in the circuit. The vacuum cycle must include an evacuation phase followed by an ascension phase, in which the system is allowed to reach an equilibrium condition. The absolute pressure at the end of this process must not exceed 150 Pa. To ensure the best performance of the machine, the vacuum process must be carried out with care and precision;
- before carrying out the vacuum, make sure that the oil in the pump used to create the vacuum is clear and free of bubbles, in order to prevent non-condensable gases or other particles from entering the system circuit. Use an ATEX vacuum pump;
- connect to the circuit charging socket with a hose and charge the refrigerant gas carefully and slowly. Shall not exceed the gas charged specified in the data sheet. Use calibrated scales (ATEX) with a reading sensitivity of at least a tenth of a gram. If available, the use of heating covers for cylinders is also recommended in order to speed up the filling phase of the circuit;
- once the desired charge has been completed, remember to insert the pin into the charging socket again and disconnect the equipment used;
- ensure the tightness of the system by monitoring for refrigerant gas leaks with a suitable detector.

Failure to comply with the rules set out in this manual may result in:

- malfunctions and loss of machine performance;
- leakage of refrigerant gas, with possible formation of an explosion hazard zone;
- damage to components or piping (e.g. freezing).



**ATTENTION: All loading/unloading operations of the machine must be carried out by QUALIFIED PERSONNEL (EN 378-4).**



**ATTENTION: During loading/unloading operations, there is always a risk of refrigerant gas leakage and thus the formation of flammable atmospheres. Take the utmost care to ensure that no refrigerant gas is present in the environment before and during each operation.**

## 5.10 PLUMBING CONNECTIONS

The plumbing connections must be made in accordance with national and/or local regulations; pipes can be made of steel, galvanised steel, multilayer steel or PVC. Pipes must be accurately sized according to the maximum water flow rate of the unit and the pressure drops of the water circuit. All pipes must be insulated with closed-cell material of adequate thickness. The chiller must be connected to the pipes using new flexible joints, not reused ones. The water circuit should include the following components.

- Well thermometers to monitor the circuit's temperature.
- Manual gate valves to isolate the chiller from the water circuit.
- Metal Y filter or a dirt separator (installed on the return pipe) with metal mesh no larger than 1 mm.
- Loading group and exhaust valve where necessary.



**CAUTION: When sizing the pipes, make sure not to exceed the maximum pressure drop on system side reported in the technical data table in Chapter 12 (see useful head).**

**Connect the pipes to their fittings always using the key-to-key method.**

**CAUTION: Create a suitable drain for the safety valve.**

**CAUTION: The expansion vessel, if present on the unit (check the hydraulic diagram), has a limited capacity. It is the installer's responsibility to check that the expansion vessel is adequate for the actual capacity of the system, otherwise an additional expansion vessel must be provided.**

**CAUTION: Place the return pipe from the system at the 'WATER INPUT' label, otherwise the evaporator may freeze.**

**CAUTION: It is mandatory to install a metal filter (with mesh no larger than 1 mm) on the return pipe from the system labelled "WATER INLET". Alternatively, it is possible to install a defangator that guarantees a filtration degree of no more than 1mm; in this case, it is no longer necessary to install the Y-filter. If the metal filter or the defangator are missing, the warranty will terminate immediately. The filter (or the defangator) must be kept clean. Therefore after installing the unit, you must make sure that they are still clean and check them regularly.**

**CAUTION: All of the units leave the company supplied with flow switch (installed in factory). If the flow switch is altered or removed or if the water filter and dirt separator are missing from the unit, the guarantee will be void. Refer to the wiring diagram attached to the unit to connect the flow switch. Never jumper connections of the flow switch in the terminal block.**

**The heating system and the safety valves must comply with the requirements of standard EN 12828.**

The unit has a pre-drill on the side cover plate in order to provide a suitable passage for the discharge of the safety valve on the water side (the installation of which is the responsibility of the user).

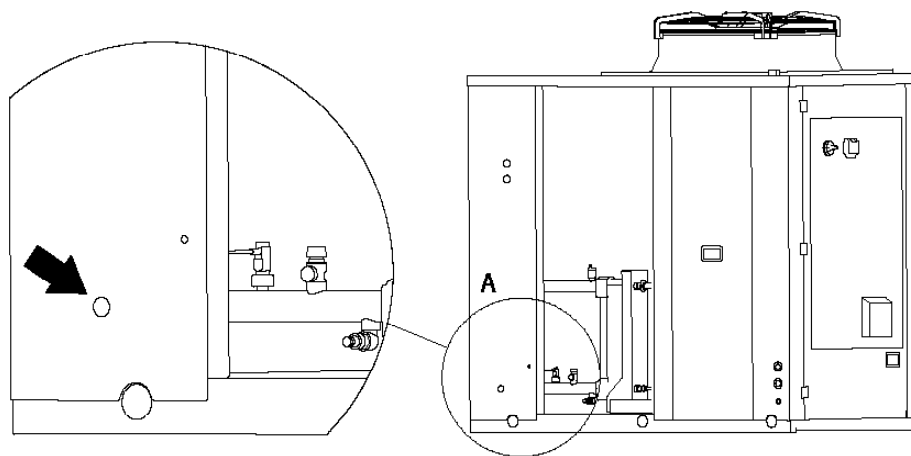

## 5.10.1 Characteristics of the circuit water

To guarantee correct operation of the unit, the water must be appropriately filtered (see the instructions at the start of this paragraph) and there must be only a minimum amount of dissolved substances. The maximum allowed values are shown below:

MAXIMUM CHEMICAL-PHYSICAL PROPERTIES ALLOWED FOR THE CIRCUIT WATER	
PH	7,5 - 9
Electrical conductivity	100 - 500 $\mu$ S/cm
Total hardness	4,5 – 8,5 dH
Temperature	$\leq 78$ °C
Oxygen content	< 0,1 ppm
Max glycol quantity (*)	10 %
Phosphates (PO <sub>4</sub> )	< 2ppm
Manganese (Mn)	< 0,05 ppm
Iron (Fe)	< 0,3 ppm
Alkalinity (HCO <sub>3</sub> )	70 – 300 ppm
Chloride ions (Cl <sup>-</sup> )	< 50 ppm
Sulphate ions (SO <sub>4</sub> )	< 50 ppm
Sulphide ions (S)	No one
Ammonium ions (NH <sub>4</sub> )	No one
Silica (SiO <sub>2</sub> )	< 30 ppm

(\*) It is preferable to use pure water. Do not add more antifreeze than the maximum quantity specified in this manual.

## 5.10.2 Hydraulic diagram inside the unit

The hydraulic connection diagrams to the unit for all the available versions and the legend valid for all the diagrams are shown below. In any case, each unit always includes a safety valve with an opening pressure of 6 bar, whatever the hydronic kit with which it is equipped.

Legend			
EV/CO	Plate heat exchanger	WF	Y-filter*
DV	Discharge valve	FC1	Flow switch
RV	Safety valve	W-IN	Water input
BV	Shut-off valve	W-OUT	Water output
HKA1	Heat exchanger resistance *	VDIS4	3-way valve *
HKA2	Pump resistance *	NR	Non-return valve
HKA3	Tank antifreeze heater *	P1 PD1/2	Pump *
VA	Expansion vessel	AV	Automatic air vent valve
*	Optional	TK	Tank *
---	Separately supplied accessory to be installed outside the unit		



STANDARD HYDRONIC CIRCUIT WITH OPTIONAL ACCESSORIES

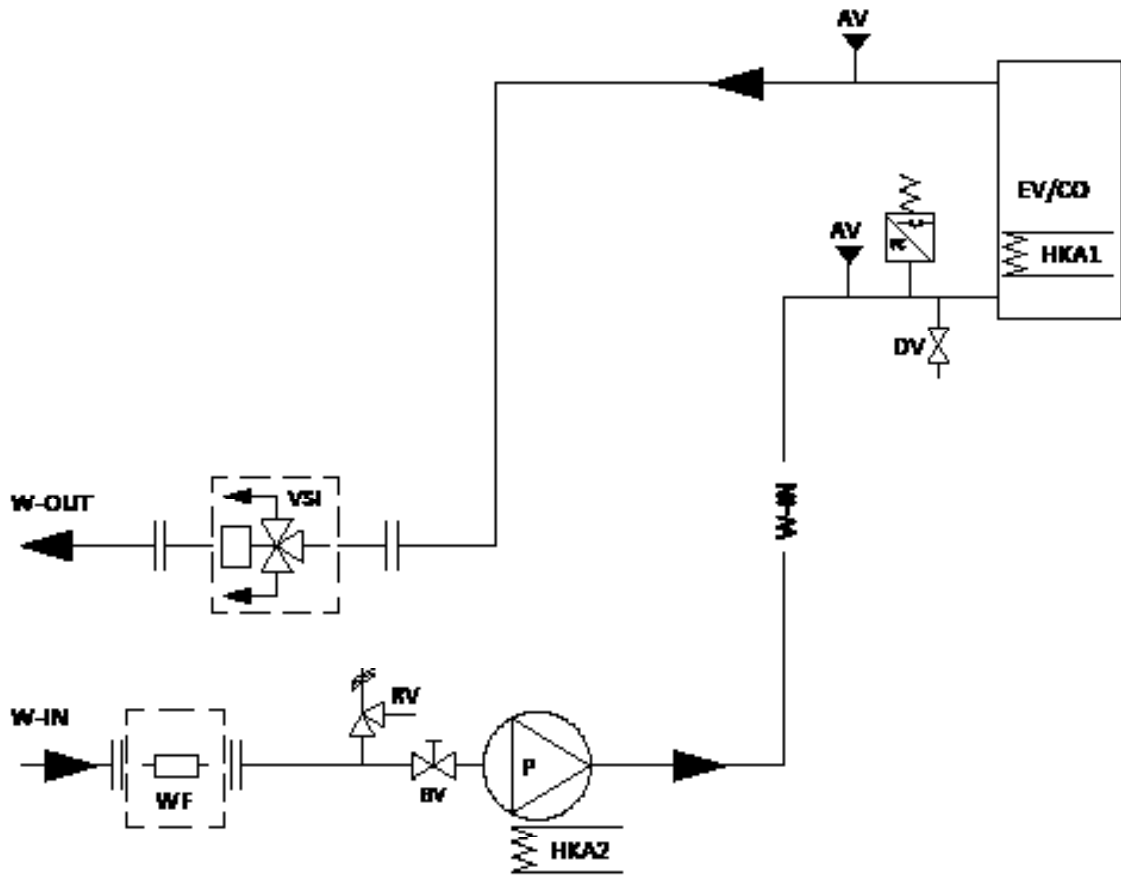

HYDRONIC CIRCUIT SINGLE PUMP VERSION (WITH OPTIONAL TANK)

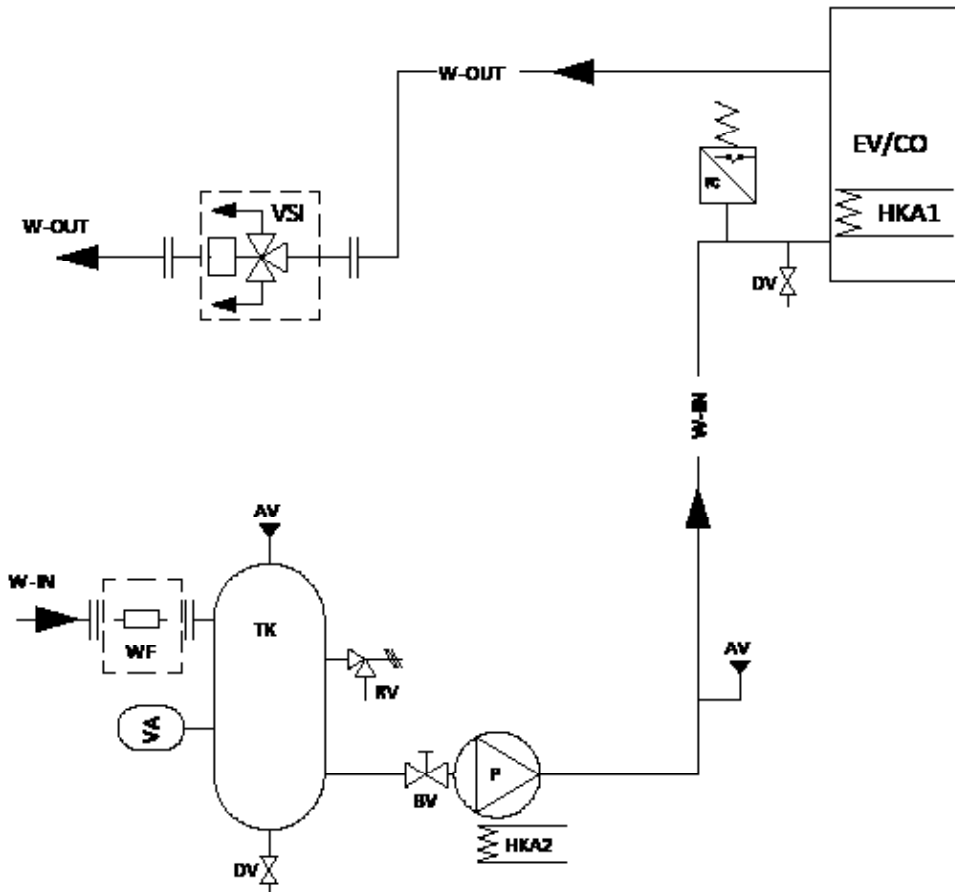



**ATTENTION:** It is recommended to connect the safety valve vent in an appropriate conveyor/discharge. Otherwise the discharged water could stagnate around the unit and become a source of danger due to slipping/falling. The point of conveyance must be outdoors and within the danger zone defined in Chapter 3.3; or at another suitable point, bearing in mind that, in the event of a leakage of refrigerant gas, the collection zone must be treated as a danger zone (Chapter 3.3).

## 5.10.3 Condensation discharge system

As the pipes are well insulated, condensation production is minimal and does not lead to the accumulation of water inside the refrigeration compartment. All heat pumps have a condensate drain hole in the base frame, which is plentiful especially in the post-defrost phase.

**Caution:** Do not obstruct the hole in the base panel for condensate drainage.

Especially in very cold climate regions, it is recommended to install elevation supports in order to allow ice formation under the unit without damaging it by freezing.



**ATTENTION:** For heat pump units, in the event that the prepared ducting system is not used, a limited amount of water (possible ice in the winter period) from the condensate drainage system may be deposited in the vicinity of the unit, posing a slip/fall hazard.

In the event of a leakage, refrigerant gas can escape from the unit through the holes in the base panel, so it is recommended that the condensate drain is always directed to an open place near the unit (within the danger zone defined in Chapter 3.3). If the unit is installed on the ground, it is also possible to direct the condensate into a bed of rubble or gravel for drainage.

## 5.10.4 System load



**CAUTION:** Supervise all filling/reintegration operations.

**CAUTION:** Before filling/reintegration the system, disconnect power to the units.

**CAUTION:** The filling / reintegrating of the system must always take place under controlled pressure (max. 1 bar). Ensure that a pressure reducer and safety valve is installed on the filling/reintegration line.

**CAUTION:** The water in the filling/reintegration line must be properly pre-filtered from impurities and suspended particles. Ensure that a removable cartridge filter and a dirt separator are installed.

**CAUTION:** Regularly check and vent the air built up in the system.

**CAUTION:** Install an automatic air venting valve at the highest point of the system.

It is advisable to use an external tap to fill the system, which is the responsibility of the installer.

There is always a service tap in the unit to be used if it is necessary to top up/discharge the amount of water in the system or adjust the percentage of glycol.

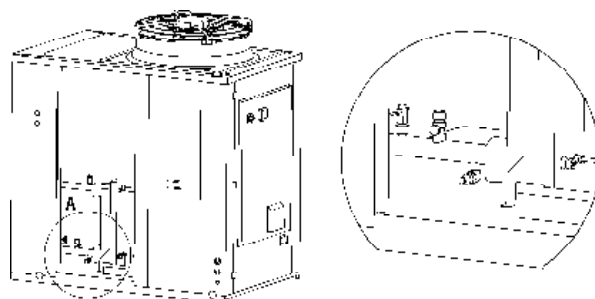

## 5.10.5 System discharge

If the unit needs to be drained completely, first close the manual inlet and outlet gate valves (not included in supply) and then detach the pipes on the outside of the water inlet and outlet to drain liquid from the unit (to make this operation easier, it is recommended to install two drain valves between the unit and manual gate valves on the outside of the water inlet and outlet).

If it is necessary to top up the system or adjust the glycol content, the service tap can be used. Unscrew the cap of the service tap (A) and connect a pipe of 14 or 12 mm (inertial diameter measurements - check the tap model installed on your unit) connected to the water mains to the hose connector, then fill the system by unscrewing the ring nut (B). Once the operation is completed, tighten the ring nut (B) again and screw the cap (A). In any case, it is advisable to use an external tap to fill the system.

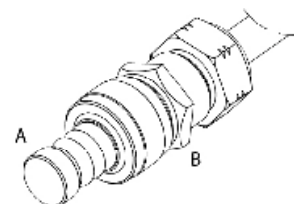



## 5.10.6 Service sleeves

The unit is fitted with an air venting valve to automatically remove air that has built up in the circuit, preventing undesirable effects such as premature corrosion and wear, lower performance and low exchange output.

The device also features a safety function because, in the event of exchanger breakdown, it allows the refrigerant gas to escape outside, preventing it from being conveyed to the internal terminals.

The valve can be kept in a closed position by closing the plug on the drain; by loosening the plug, the valve remains in open position and air is discharged automatically.

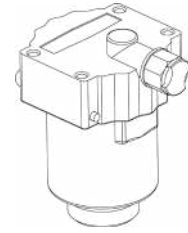

**If you notice a water leak, you must replace the component by unscrewing it with a spanner, as shown in the image below.**



## 5.11 FUNCTIONAL DIAGRAMS

LEGEND			
INVC	VARIABLE SPEED COMPRESSOR	RS	SUCTION LINE
CO/EV	CONDENSER (IN CHILLER OPERATION)	RD	DISCHARGE LINE
EV/CO	EVAPORATOR (IN CHILLER OPERATION)	RD/RS	DISCHARGE/SUCTION LINE
EEV	ELECTRONIC EXPANSION VALVE	RS/RD	SUCTION/DISCHARGE LINE
MAF	VARIABLE SPEED AXIAL FAN	RL	LIQUID LINE
CV	NON-RETURN VALVE	W-IN	WATER SYSTEM OUTLET LINE
Y4W	4-WAY VALVE FOR CYCLE REVERSAL	W-OUT	WATER SYSTEM INLET LINE

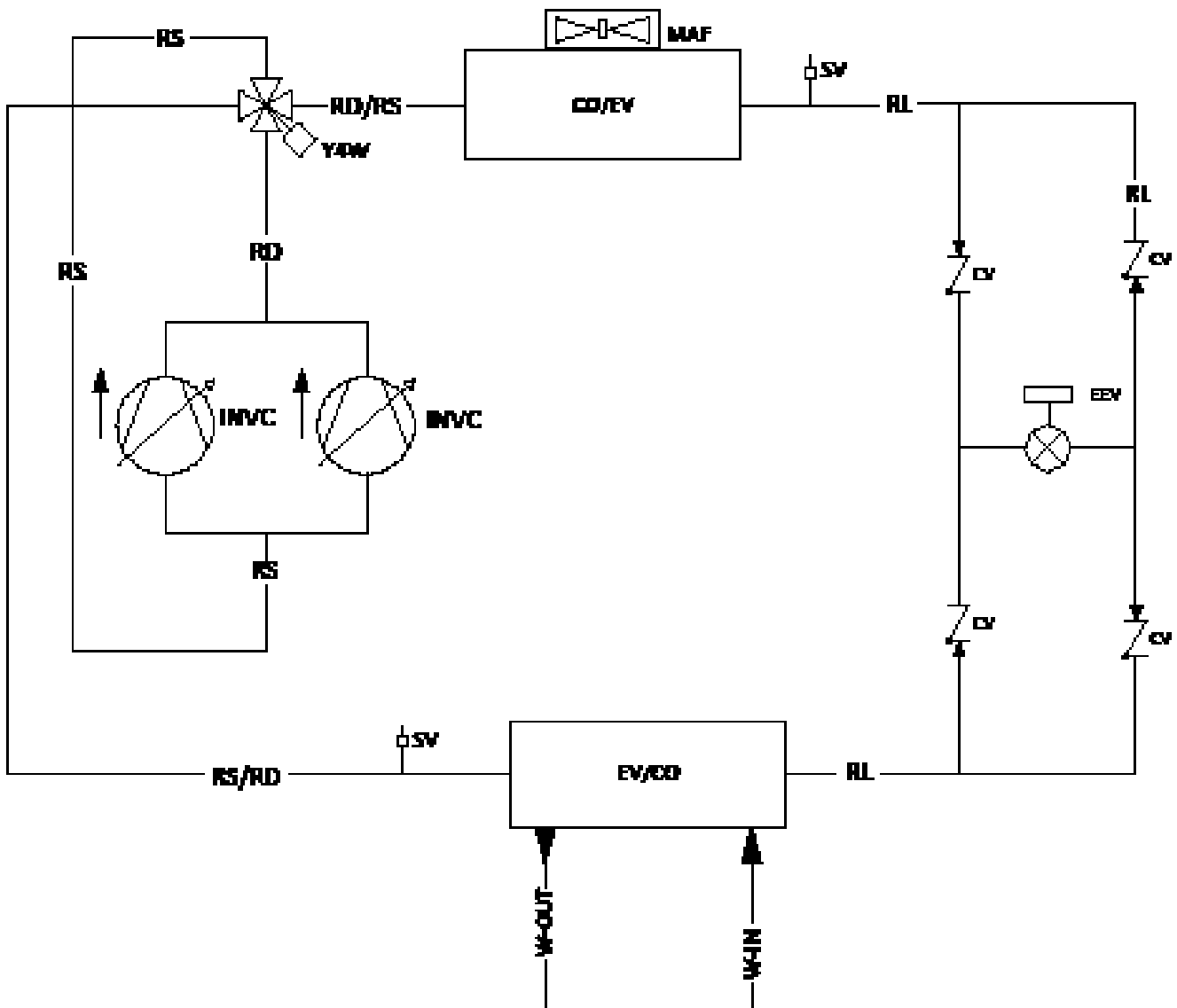

## 5.12 ELECTRICAL CONNECTIONS

Check that the power supply matches the unit's electric nominal data (voltage, phases, frequency) displayed on the rating plate on the unit's side panel. The electric power connections must be made in accordance to the wiring diagram enclosed with the unit and in conformity with national and international standards (providing general circuit breaker, residual current devices for each line, proper earthing of the plant, etc.).

	Before starting any operation, make sure that the power supply is disconnected.
	The electrical panel is positioned below the cover. Respect the minimum clearances reported in Chapter 5.4 to perform wiring.
	The installer is responsible to provide an isolating system (e.g. magnetothermal differential circuit breaker) upstream of the unit's electrical connections.
	The supply voltage must not vary by more than $\pm 10\%$ of the nominal value. Please contact the electricity supply company if this tolerance is not respected. The power supply must comply with the limits mentioned, otherwise the warranty shall expire immediately.
	If the supply cable is damaged, it must be replaced by qualified personnel, (EN 378-4), in order to prevent any risk.



	Any devices placed nearby can cause / suffer electromagnetic disturbances to/from the unit. Be aware of this risk at the installation site. It is recommended to electrically power the unit with an adequate line and protections and use an independent cable duct.
	The flowmeter (FM element in the hydraulic diagram above and factory installed) must ALWAYS be connected as shown in the circuit diagram. Never jumper the flowmeter connections on the board in the terminal box. The guarantee will no longer be valid if the flowmeter connections have been altered or incorrectly connected.
	All electrical components have been designed to work in an environment where R290 gas is present. Any damage, tampering or alteration can cause a fire hazard.
	Do not tamper with the cable fixing. Do not disconnect the electrical panel connectors.

For the correct wiring diagram, please refer to the documents enclosed with the units.

Unit size	Installed accessory	Circuit diagram code
40 kW / 50 kW	-/PSI	FF0207XXXX000
	PS	FF0207XXXX001
	PSEC	FF0207XXXX002

XXXX - variable numbers

## 5.12.1 Access to electric panel

The electrical panel is accessible even when the machine is closed and is located on the compressor side. In order to open the panel door, it is necessary to set the disconnecting switch to OFF and use a double-finned key in both locks.

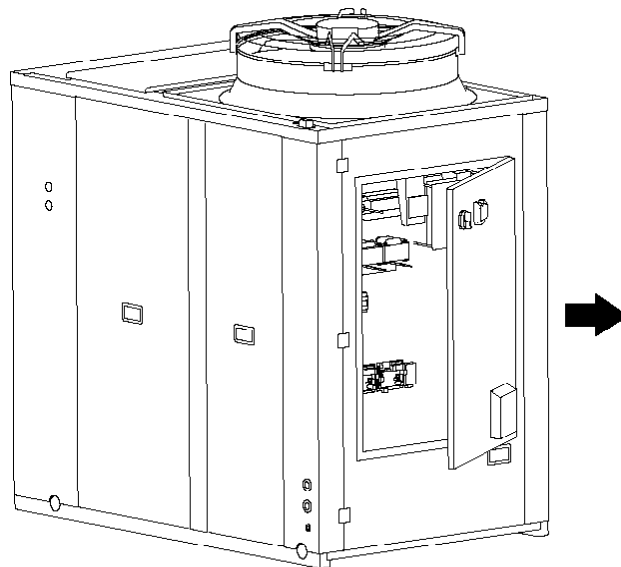

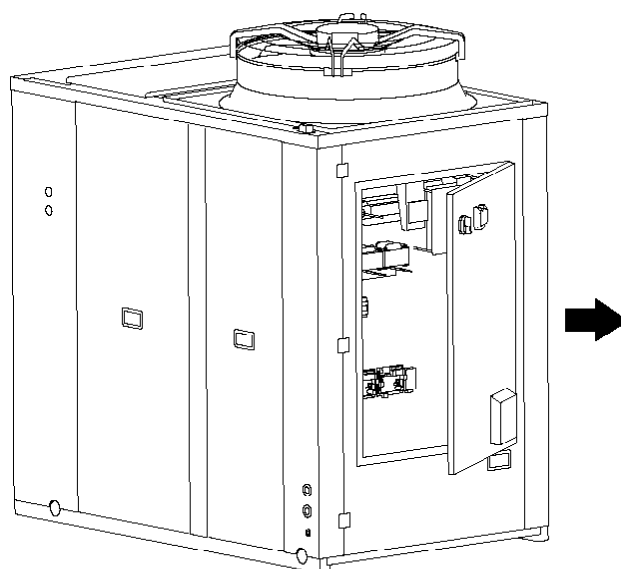

## 5.12.2 Power supply



The electrical wiring to the terminal blocks has to be done only by qualified personnel.



Make sure to install an adequate ground connection, incomplete grounding can cause electric shock. The manufacturer cannot be held responsible for any damage caused by failure or ineffective earthing.

The power cables, electrical protections and line fuses must be sized in accordance with what is reported in the unit's wiring diagram and in the electrical data contained in the technical characteristics table.

Use a dedicated power line, do not power the appliance through a line to which other users are connected. Fasten the power cables securely and make sure they do not come into contact with sharp corners. Use double insulated cables with copper wires.

The ground connection must be carried out first during the connection phase, vice versa it must be removed last when the unit is disconnected. In the event of any loosening of the power cable, it must be ensured that the tension of the active conductors takes place before that of the ground wire.

Arrange for the laying of the building's electrical cables through the wall feedthrough in the direction of the product. Depending on the type of laying, the physical location and the length of the cables (whether less or more than 10 m), it will be the responsibility of the electrical system designer to make an appropriate choice for the dimensioning of the system.

## 5.12.3 Protection devices

It is mandatory to install electrical separation devices upstream of the unit, sized according to the nameplate data on the unit:

- For electrical protection, delayed fuses with a T or R characteristic must be used; the fuses must be able to be disconnected at all poles and must have a contact opening of at least 3 mm; alternatively, a circuit breaker with a C characteristic with a breaking capacity of 4.5 kA or more must be used.
- If prescribed for the installation site, install an earth leakage circuit breaker. F or B type is recommended; installation of a different type of circuit breaker could result in untimely tripping.

Power supply	Model	Recommended cable cross-section	Recommended tightening torque
50Hz 400V / 3ph + N +PE	40 kW / 50 kW	*5G16	L1/L2/L3: 3,4 Nm – N/PE: 3,7 Nm

(\*) H07RN-F cable fixed in air at 30°C.

The units comply with electromagnetic compatibility specifications, however, the electrical system designer must make appropriate assessments to ensure the absence of interference.

During installation, the designer must dimension the external protection devices considering a short-circuit current (Icc) of 10kA.



**WARNING: the leakage current is greater than 10mA. It is mandatory to follow the installation rules given in chapter 8.2.6 of IEC 60204-1:2016 / EN 60204-1:2018.**

## 5.12.4 User terminal block

The connection terminal block is located under the machine cover. For access, see the instructions. The terminal block must be connected respecting the notes below.

The connections shown below are standard. Other connections are given in the MCO manual of the on-machine control (see "USER AND INSTALLER CONFIGURATION TABLES"), according to the configurations adopted.



**CAUTION:** It is important to keep the high voltage cables separated from the very low voltage ones.

Terminal	Connection	Type
PE	Connect the ground wire	Power input 3-Ph/N/PE, 400 Vac, 50Hz
N	Connect the neutral cable from the mains	Power input 3-Ph/N/PE, 400 Vac, 50Hz
L1	Connect L1 phase cable from the mains	Power input 3-Ph/N/PE, 400 Vac, 50Hz
L2	Connect L2 phase cable from the mains	Power input 3-Ph/N/PE, 400 Vac, 50Hz
L3	Connect L3 phase cable from the mains	Power input 3-Ph/N/PE, 400 Vac, 50Hz
XC-1.1	Modbus RTU primary connection GND for remote keyboard	Modbus communication RS RTU RS 485
XC-1.2	Modbus RTU - primary connection for remote keypad	Modbus communication RS RTU RS 485
XC-2.1	Modbus RTU + primary connection for remote connection	Modbus communication RS RTU RS 485
XC-3.1	Modbus RTU GND secondary connection for remote keyboard	Modbus communication RS RTU RS 485
XC-3.2	Modbus RTU - secondary connection for remote keyboard	Modbus communication RS RTU RS 485
XC-4.1	Modbus RTU + secondary connection for remote connection	Modbus communication RS RTU RS 485
XC-5.1 / XC-5.2	Remote on/off unit (close=unit on / open=unit off)	Voltage free digital input
XC-6.1 / XC-6.2	SGReady 1 input or Remote summer/winter mode change (to activate the function see relevant paragraph in the MCO manual)	Voltage free digital input
XC-10.1 / XC-10.2	SGReady 2 input or Storage/domestic/remote sensor input (to activate the function see relative paragraph in MCO manual)	Free digital voltage input / Configurable analogue input (probe NTC- 10kΩ a 25°C β 3435).
XP-2.1 / XP-2.2	DHW valve control (to activate the function see the relevant section in the MCO manual)	Voltage output 230Vac, 50Hz, 2A (AC1)
SS-1 / SS-2	Connection for sensor alarm signalling	Voltage output 24V
SF-1 / SF-2	Connection for sensor warm-up/fault signalling	Voltage output 24V

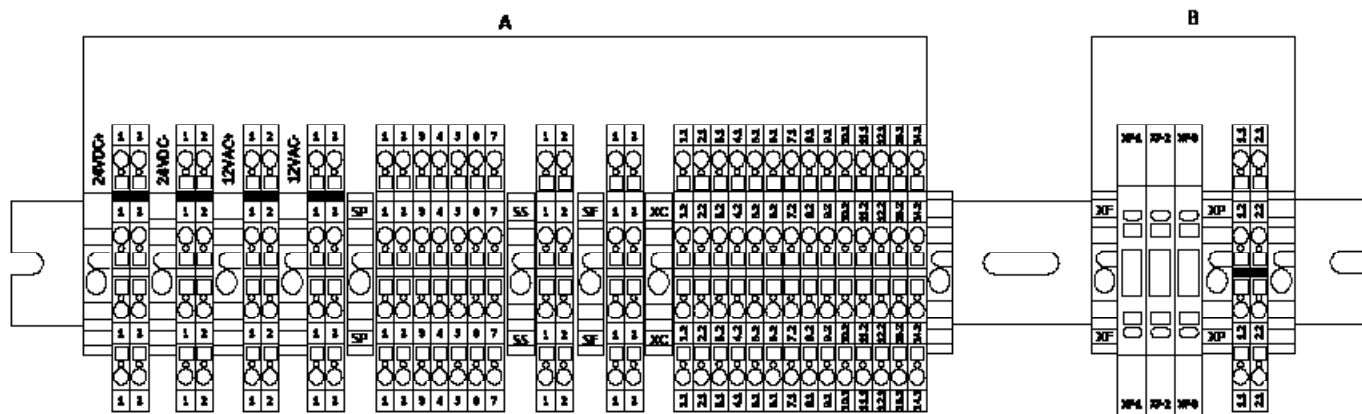

A	Control terminal block
B	Power terminal block



### 5.12.5 Refrigerant gas leak detection sensor

Each unit is equipped with an autonomous refrigerant detection system inside the compartment of the refrigerant circuit to monitor possible leakage of refrigerant gas.

In order to ensure optimal performance and avoid poisoning by polluting particles, it is necessary to calibrate the sensor at least every 12 months. The sensor works automatically and autonomously, so no user intervention is required.

On the door of the unit electrical panel, there are two LEDs that trigger according to the operating status of the unit (see the table below).



Condition	LED	Unit is powered?	Duration	Implemented action
First unit start-up		NO	5 min	Wait until the end of the warm-up period
Normal operation	-	YES	-	Normal thermal regulation of the unit
Fault / Over-range		NO	-	<ol style="list-style-type: none"> <li>1. Manually check for refrigerant leaks in the room - do not introduce possible ignition sources near the unit.</li> <li>2. Disconnect + reconnect power supply.</li> <li>3. Contact a service center</li> </ol>
Alarm threshold (LFL $\geq$ 20%)		NO	-	<ol style="list-style-type: none"> <li>1. Manually check for refrigerant leaks in the room - do not introduce possible ignition sources near the unit.</li> <li>2. Automatic reset when refrigerant concentration falls below the trip threshold.</li> <li>3. Contact a service center.</li> </ol>

	<b>CAUTION:</b> In case of sensor fault, contact immediately the company. Do not operate the unit.
	<b>CAUTION:</b> In the event of sensor, some parts of the electrical panel are still energized even though the machine display is off. Take all necessary precautions and wear the appropriate PPE. For any maintenance operations on the electrical panel, set the switch disconnecter to the "OFF" position.
	<b>CAUTION:</b> After the sensor has measured a refrigerant gas concentration that exceeds the alarm threshold and the unit is consequently shutdown, always check the presence of refrigerant gas in the environment using a suitably calibrated R290 leak detector. Only once the absence of gas in the danger and safety zones of the machine has been verified, it is possible to proceed with the manual reset of the sensor.
	It is forbidden to disconnect the sensor from the unit or change its position. The installation position of the gas detector is always vertical, with the sensor head downwards.
	Do not drill or mechanically alter the sensor housing.
	The sensor shall be kept clean of liquids, dust, and other particles. Periodically check the sensor head for deposits and, if so, clean the sensor properly with cloths that do not accumulate electrostatic charges. The gas detector must be cleaned in such a way that there is no risk of infection. It is forbidden to clean the sensor with compressed air. In case of defects or damage on the sensor, immediately contact an authorized service center to perform maintenance inspection and calibration of the gas detector.
	<b>CAUTION:</b> Exposure to silicones, silicates, silanes substances containing chlorine, iodine, bromine, fluorine and other halides seriously affects the performance of the sensor or it can even lead to total failure.
	<b>CAUTION:</b> If the sensor is exposed to concentrations exceeding the measuring range (over-range), its zero point or sensitivity may change significantly: always have the operating status of the sensor checked by an authorized service center after each intervention of the detector, which, if necessary, will proceed with a new calibration or replacement (if required).
	<b>CAUTION:</b> Periodic maintenance and calibration of the sensor is mandatory, with a maximum frequency of 12 months (see chapter 9.3). Maintenance and calibration of the sensor must be carried out only by qualified personnel. In atmospheres contaminated with pollutants, periodic calibration must be performed more frequently to ensure the reliability of the component. It is the responsibility of the plant designer to assess the typical working atmosphere of the unit in relation to the presence of contaminants and to identify the correct maintenance and calibration interval, which in any case cannot exceed 12 months. The calibration interval must in any case comply with the national laws and regulations in force in the country where the unit is installed. Use the most restrictive calibration interval available.

## 15.1.1 Smart Grid Ready

The SHP290 heat pumps are Smart Grid Ready (SG Ready) certified, a label introduced by the German Heat Pump Association (BWP) that identifies heat pumps capable of communicating with the public electricity grid via the SG Ready interface. This allows the electricity utility an efficient load management for grid support: in case of electricity peaks or shortages, the grid operator can give the input to heat pumps equipped with SG Ready logic to temporarily switch off or on, achieving intelligent utility control.

Heat pumps, regardless of current demand, can in fact store excess electricity in the form of thermal energy (e.g. in a hot water accumulator or a dedicated tank) and use it to satisfy heat demand, as well as being switched off in a targeted manner to mitigate consumption peaks.



The SG The SG Ready interface can be used by grid operators to control the device or to increase self-consumption in combination with a photovoltaic system.

To enable the SG Ready function, the grid supplier's SG Ready cables must be connected to the user board's terminals ID2, C (digital input reference ID2 = SG Ready 1) and A18, C (digital input reference ID9 = SG Ready 2). Depending on the states of the two digital inputs for the SG Ready function, the unit is able to cover four operating states (heating and/or DHW mode):

Digital input		Description
ID 2 (SG Ready 1)	ID9 (SG Ready 2)	
Closed	Open	OFF command The heat pump remains in the forced-off condition.
Open	Open	Normal operating.
Open	Closed	Command ON The heat pump increases the set point by an offset, applying it only when the compressor and/or thermoregulation is running.
Closed	Closed	Forcing command ON The heat pump immediately forces an offset set point increase, regardless of the compressor status.

The operating states OFF, ON and forced ON can be set by the grid operator for a maximum time of 2 hours, after which the unit reverts to normal regulation.



**ATTENTION:** If the power grid to which the unit is connected is set up as a smart grid, the SG Ready function can be configured according to the MCO manual and the wiring diagram.

Heat pumps labelled 'SG Ready' are a step towards electricity supply optimisation and are eligible for further funding in some EU member states.

## 5.12.6 Control logics

For control logics please refer to the MCO manual of unit control, which can be obtained from the manufacturer.

## 5.12.7 Fuses

Details of the type and nominal characteristics of the fuses can be found on the machine label, on the circuit diagrams and printed directly on the control board.

## 5.13 EXTERNAL MODULE (GI3)

The GI3 system management module allows you to increase the functionality managed by the machine. It is only supplied as an external kit.

### 5.13.1 NET DIMENSIONS AND WITH PACKAGING

Description	Width [mm]	Height [mm]	Depth [mm]	Weight [kg]
net	261	317	128	5,3
with packaging	372	422	185	5,6

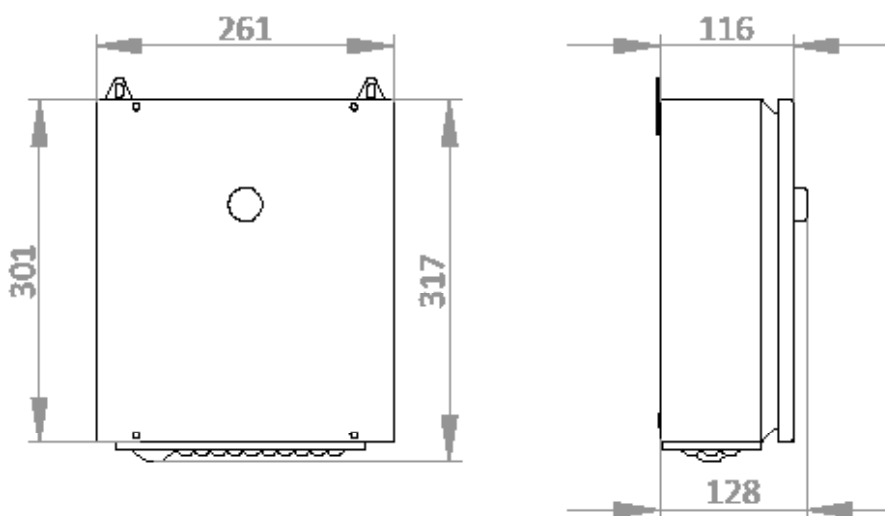



## 5.13.2 Technical data

Technical characteristics	Unit	Value
Supply voltage	V	230
Supply frequency	Hz	50
Maximum power absorption	kW	1,5
Maximum current for DO	A	0,5
Min/Max ambient operating temperature	°C	-20 / +50
Operating weight	kg	5,3

## 5.13.3 Installation of external kit (GI3)

The product has an IPX4 protection rating and can be installed outdoors away from the safety zone of the unit.

The box is supplied with brackets for fixing with nuts and washers. Refer to the pictures below for mounting the supports to the box and for drillings. The dowels are not supplied, choose the most suitable ones according to the type of wall where the product will be fixed and the weight shown in the table.

	<b>Check the safety distances in Chapter 5.5. The product is not suitable for installation in areas where explosive atmospheres may occur.</b>
	<b>Check that the supporting wall and dowels are adequate to support the weight of the product.</b>

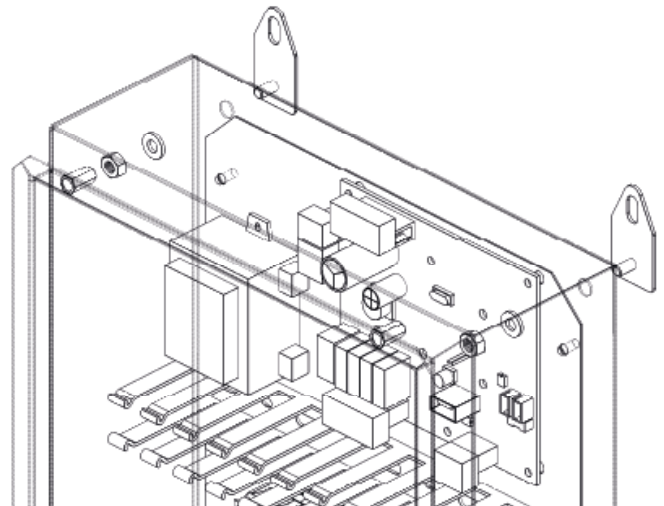
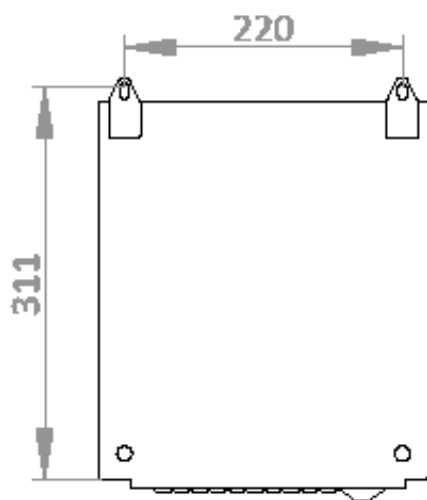

Connect the external kit to the heat pump via a cable suitable for modbus communication (cable not supplied, type to be used 3x0.5 mm<sup>2</sup> twisted and shielded). See the correspondence between the terminals of the user card and those of the kit in the table below:

Heat pump terminal	External kit terminal
XC-3.1 (GND)	X-14.2
XC-3.2 (-)	X-14.1
XC-4.1 (+)	X.15.1

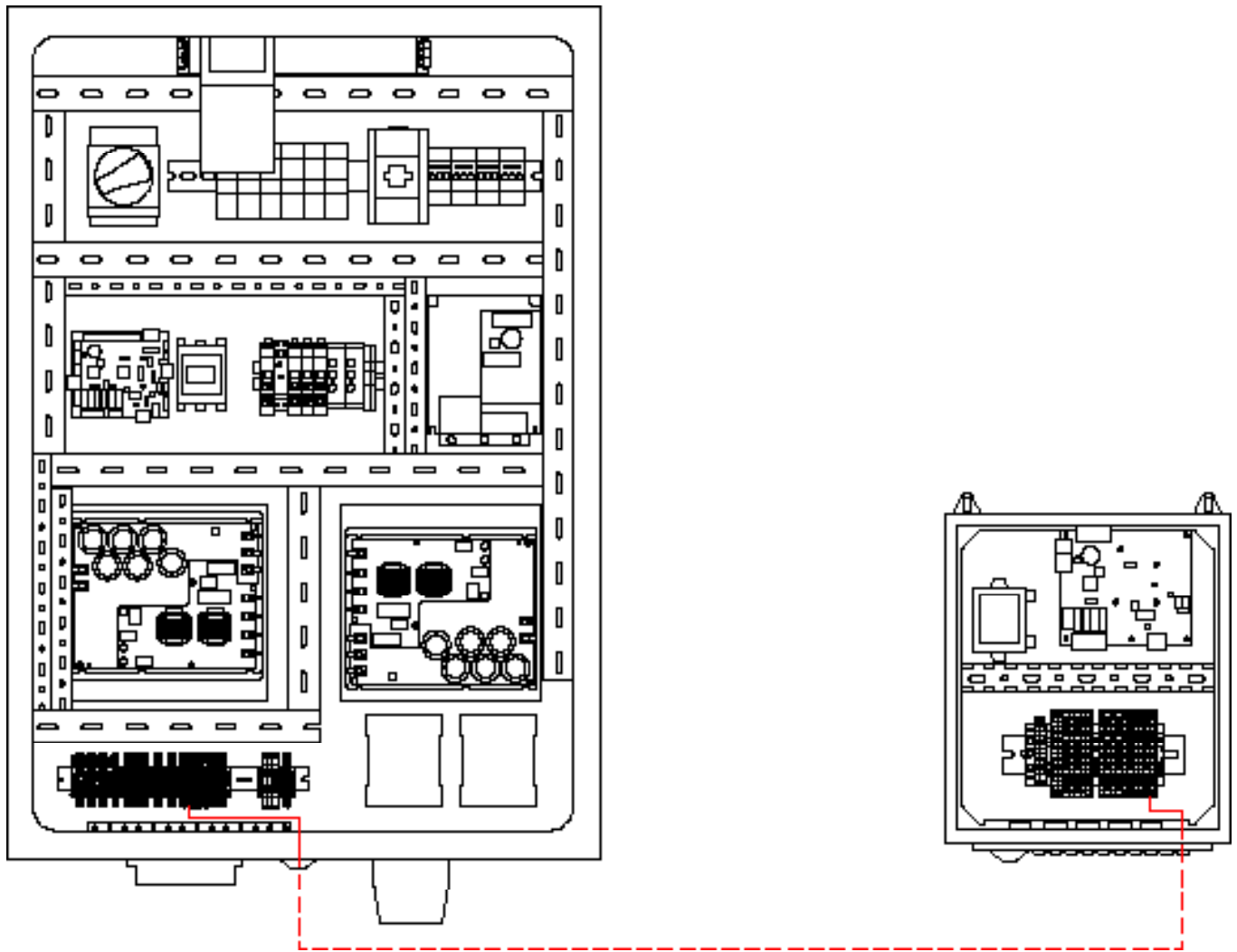

External module terminal block:

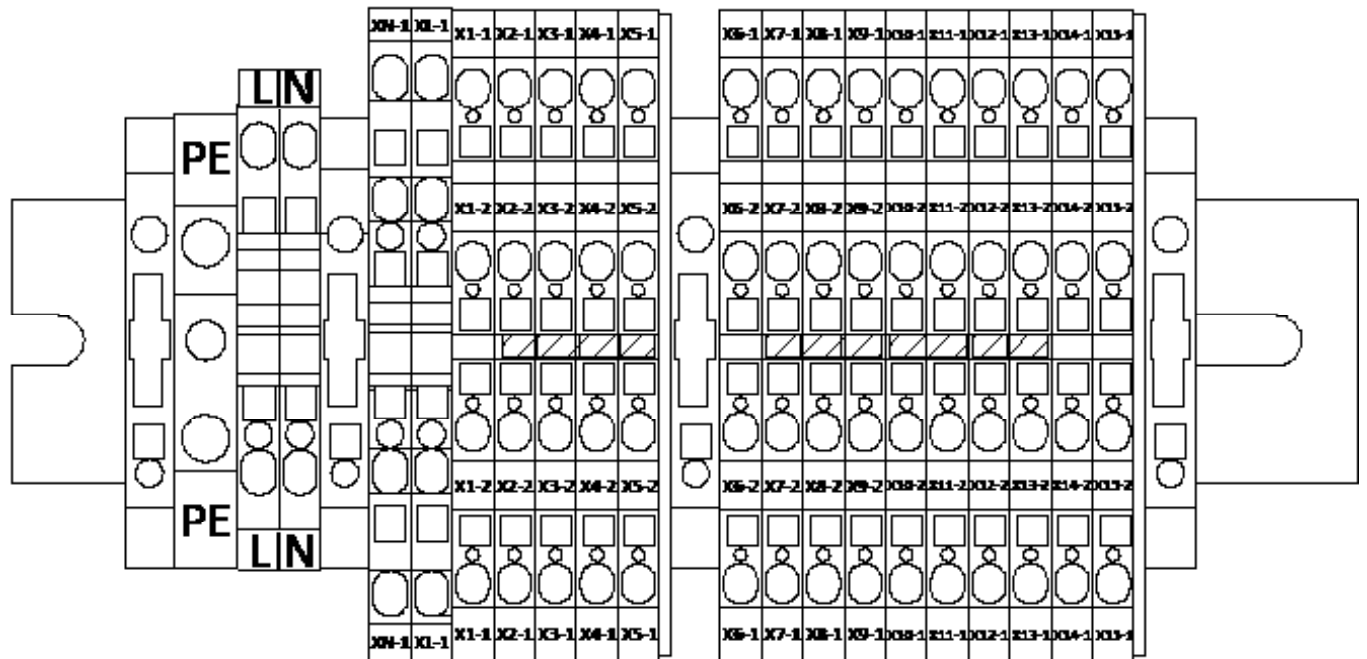



TERMINAL	CONNECTION	TYPE
PE	Connect the earthing cable	Input for 1-Ph/N/PE power supply, 230V, 50Hz
L	Connect the phase cable from the mains	
N	Connect the neutral cable from the mains	
X1-1/ X2-1/ X2-2	Connect the mixing valve	Digital outputs
X3-1/ X3-2	Connect the solar circulator	
X4-1/ X4-2	Connect the solar drain valve	
X5-1/ X5-2	Connect the relaunch circulator	
X6-1/ X6-2	Connect the mixing valve probe	Analogue inputs
X7-1/ X7-2	Connect the ACC. solar probe	
X8-1/ X8-2	Connect the solar connector probe	
X9-1/ X9-2	Connect the ambient thermostat	
X10-1/ X11-1	/	Analogue outputs
X10-2/ X11-2	/	
X12-1/ X12-2/ X13-1	/	Digital inputs
X14-1/ X14-2/ X15-1	Modbus connection to the machine's CNTR board	Modbus communication

## 6. STARTUP

Before start-up:

- Check that the diagrams and manuals of the installed machine are available.
- Check the availability of electrical and hydraulic diagrams of the system to which the machine is connected.
- Check that the shut-off valves of the water circuits are open.
- Check that the water circuit was filled under pressure and the air vented.
- Check that all hydraulic connections are correctly installed and that all indications on the rating plates are respected.
- Ensure that provisions have been made for condensate drainage.
- Check the electrical connection and correct fastening of all the terminals.
- Check that electrical connections have been carried out correctly according to current regulations including earthing.
- The voltage must be as stated on the nameplate of the unit.
- Make sure that the electric voltage is within the tolerance limits ( $\pm 10\%$ ).
- Check that the electric heaters of the compressors are properly powered.
- Check, if required for the installation site, whether a residual current circuit breaker is installed.
- Check that there are no gas leaks. Each operator must equip himself with a personal explosimeter for R290 gas.
- Before switching the unit on, check that all panels are positioned correctly and well-fixed with screws.
- When switching on the machine, check that no more of one defrost is activated in the first 35 minutes of operation. Multiple consecutive defrosts may indicate incorrect sizing of the unit with respect to the thermal load required by the application.

	<b>CAUTION:</b> The unit must be connected to the electric mains and placed in <b>STANDBY (powered on)</b> by closing the master switch at least 12 hours before start-up. This will allow the heaters to adequately warm up the compressor crankcase (the heaters are powered automatically when the switch is closed). The heaters are working properly if after a few minutes the temperature of the compressor crankcase is 10-15°C higher than ambient temperature.
	<b>CAUTION:</b> Check that the weight of the pipes does not bear upon the machine structure.
	<b>CAUTION:</b> Never use the master switch to stop the unit temporarily, this must only be done to disconnect the unit from the power supply for long downtimes (e.g. seasonal stops etc.). Furthermore power is missing, the crankcase heaters will not be powered with the risk of breaking the compressors when the unit is switched on.
	<b>CAUTION:</b> Do not modify the electrical connections of the unit otherwise the warranty will be immediately void.
	<b>CAUTION:</b> Summer/winter operation must be selected at the beginning of the relative season. In order not to cause damage to the compressors, avoid frequent and sudden changes of this operation.
	<b>CAUTION:</b> When installing and starting up for the first time, make sure that the machine operates correctly in both heating and cooling mode.

### 6.1 SWITCHING ON THE UNIT

To power up the machine, turn the external handle of the isolating switch to the ON position (marked 'I'). The display on the machine will only light up if the phase sequence is correct (check during initial start-up). Wait at least 1 minute between switching off and switching on again. The display is only switched on after the refrigerant gas leakage detection sensor has finished its heating cycle and is operating correctly (approx. 5 minutes).

## 7. INSTRUCTIONS FOR THE USER

Write down the unit's identification data to be able to give it to the assistance centre when requesting an intervention.



The identification plate applied on the machine has all of the technical and performance data of the appliance. In case of tampering, removal or deterioration, ask to the Technical Assistance Service for a copy.

Tampering, removal and deterioration of the identification plate complicates installation, maintenance and request for spare parts.

We recommend keeping track of the interventions carried out on the unit so as to make any troubleshooting easier. In case of failure or malfunctioning:

- check the type of alarm triggered to report it to the assistance centre;
- contact an authorised assistance centre;
- if requested by the assistance centre, immediately deactivate the unit without resetting the alarm;
- require the use of original spare parts.

## 8. SHUTDOWNS FOR LONG PERIODS

The shutdown mode of the plant depends on the site of application and the time the plant is expected to be shut down. If the unit is equipped with the antifreeze system, even when off ("off" position of the on-board unit system).



The anti-freeze system remains in operation if the continuity of electrical supply to the appliances is guaranteed.

The leakage detection system remains in operation if the continuity of electrical supply to the appliances is guaranteed.

If the system is expected to remain idle for a long period, it is recommended to empty the liquid from the system unless there is an adequate amount of glycol.

To switch off the unit completely after having emptied the system:

- Switch off the unit setting the switch of each appliance at "OFF".
- Close the water taps.
- Set the general residual current device at "OFF" (if installed upstream of the system).



If the temperature drops below zero there is serious danger of frost: provide a mixture of water and glycol in the system, otherwise drain the water system and the circuits of the heat pump.



**CAUTION:** Before switching on the unit, check that the temperature of the water entering the unit is higher than the minimum permissible temperature for start-up, as stated in the operating envelopes in Chapter 13.4.

## 9. MAINTENANCE AND PERIODIC CHECKS



**CAUTION:** All the operations described in this chapter must be carried out by **QUALIFIED PERSONNEL** only (EN 378-4). The end user is forbidden to undertake any modification, repair or maintenance of the product. Before performing any intervention on the unit or accessing internal parts, make sure you have disconnected power.



**CAUTION:** Before starting to operate, safety checks must be performed to ensure the combustion hazard is reduced to the minimum. The work must be undertaken according to a controlled procedure, to reduce to the minimum the risk of flammable gases or vapours while performing the work. The area must be checked with an appropriate refrigerant fluid detector before and during the work.



During any work carried out on the machine, the operator must always equip himself with a personal explosimeter for detecting the refrigerant gas R290, calibrated to a maximum threshold of 20 %LFL (this device must be compliant for use in fire risk zones and not be a source of ignition).



Maintenance must only be carried out in weather conditions suitable for the intended operations.



For maintenance, the use of a lock-valve is strongly recommended (refrigerant circuit access valve) for hooking up with hoses (hose), in order to avoid gas leaks and risk of burns.



During maintenance operations, when the machine is not connected to the power supply, the gas detection sensor on board the unit is also disconnected. It is important, therefore, that each operator is equipped with a personal explosimeter for detecting R290 refrigerant gas, calibrated to a maximum threshold of 20%LFL (this device must be compliant for use in fire-risk areas and not be a source of ignition).



	<b>CAUTION:</b> It is possible that a certain quantity of oil from the compressor is deposited in the pipes of the refrigeration circuit, especially by bends. In case of maintenance operations in which it is necessary to unsolder the pipes, it is strongly recommended to proceed with the cutting of the same and not with the disordering with a torch, as the flame triggers any oil present.
	It is prohibited to fill the refrigerant circuits with a refrigerant other than that indicated on the identification plate. Using a different refrigerant can cause serious damage to the compressor.
	It is prohibited to use oils other than those indicated in this manual. Using a different oil can cause serious damage to the compressor.
	The head and discharge pipe of the compressor are at quite high temperatures.
	Be careful when working near the condensing coils. The aluminium fins are very sharp and can cause serious injuries.
	Always use appropriate personal protective equipment.
	After the maintenance operations, close the panels by fixing them with screws. Pay particular attention to the correct closing of the electrical panel box.
	After maintenance work, pay attention to the correct positioning of the electrical cables in the respective cable glands of the user board case.
	In the event of work/building work in the vicinity of the unit, consider whether it is necessary to switch off the unit, drain it of refrigerant or protect it with suitable protection. If the product is in an area where vehicles are operating, install adequate collision protection.
	It is recommended to have specialised personnel perform periodical inspections and maintenance. The EU regulation n.517/2014 establishes that users must perform regular inspections on the plants, checking water tightness and eliminating any leaks as quickly as possible. Verify the mandatory nature and the documentation required in regulation n.517/2014 and its subsequent amendments or repeals.

Plan all maintenance activities necessary for the safety of the unit. The following are the recommended (R), and mandatory (M), activities for correct operation of the unit. The mandatory activities must be carried out by an authorised customer service which issues a corresponding certificate. Failure to comply with these activities will entail forfeiture of the warranty and could considerably shorten the service life of your product.

OPERATION	M / R	1 month	4 months	6 months	12 months
Filling the water circuit.	R	x			
Presence of bubbles in the water circuit.	R	x			
Check the proper working of the safety and control devices.	M	x			
Check that there are no oil leaks from the compressor.	R	x			
Check if there is a possible water leakage from the water circuit.	R	x			
Check that the flowmeter works properly.	M	x			
Check that the crankcase heaters are powered and running.	R	x			
Clean the metal filters of the water circuit.	M	x			
Clean the finned coil with compressed air or water jet.	R		x		
Check that the electric terminals both inside the electric panel and in the terminal blocks of the compressor are well tightened.	M		x		
Tightening of plumbing connections.	R		x		
Factory tightening torques.	M				x
Check fixing and balancing of the fans.	R		x		
Clean the air filters in the electrical panel or replace them if necessary (when present).	M		x		
Correct electric voltage and phase imbalance (without load and under load).	R			x	
Correct absorption.	R			x	
Check the refrigerant charge and eventual leaks.	M			x	



OPERATION	M / R	1 month	4 months	6 months	12 months
Check the operating pressure, superheating and sub-cooling.	R			x	
Circulation pump efficiency.	R			x	
If the unit should be out of service for a long period, drain water from the pipes and from the heat exchanger. This operation is necessary if, during seasonal stoppages, ambient temperature is expected to go down below the freezing point of the employed fluid.	M			x	
Check for corrosion/oxidation.	R				x
Check panel fastening.	R				x
Check the water quality (see chapter "5.10.1 System water characteristics") and the glycol concentration, if any.	M			x	
Check the pressure drops of any filter driers on the liquid line.	R			x	
Check the hydronic side safety valve according to EN 806-5.	R			x	
Cleaning the sensor with damp cloths.	R			x	
Recalibrating the sensor and checking the safety chain.	M				x

## 9.1 GENERALITY

To correctly clean the coil, follow the instructions below:

- Remove any superficial filth. Debris such as leaves, fibres etc. must be removed without a vacuum cleaner (use a brush or another soft tool carefully avoiding scratching with metal or abrasive parts). If you use compressed air, pay attention to keep the air flow perpendicular to the surface of the coil in order not to bend the aluminium fins. Pay attention not to bend the fins with the nozzle of the compressed air lance.
- Rinse. Rinse with water. It is possible to use chemical substances (specific detergents for finned coils). Rinse the coils by letting the water run inside each individual passage of the fins, until they are perfectly clean. Pay attention to direct the water jet perpendicular to the surface of the coil in order not to bend the aluminium fins. Do not strike the coil with the water hose. Apply your thumb at the end of the hose to increase the pressure of the water jet instead of using specific nozzles which could damage the coil.

### 9.1.1 Cleaning the filled coil treated with the anti-corrosion method

The anti-corrosion treatment applied to the finned coils (available as an alternative to the standard coils) guarantees protection against aggressive atmospheres.

The frequency of cleaning depends on the environmental conditions and is left to the common sense of the maintenance staff. When oxidizing dust or grease particles are observed on the battery surface, cleaning is recommended. In general, in a slightly polluted atmosphere, it is recommended to carry out the cleaning treatment every three months.

Washing should be carried out with preferably hot water (40-60 °C) and detergent with neutral pH, while rinsing is carried out with abundant fresh water (50 l / m<sup>2</sup>).

If the maintenance staff observes a lack of protective cover on the edge of the fins, it is necessary to contact the nearest service center to proceed with a new application of the cover and completely restore the protection against corrosion.

	<b>CAUTION: Do not clean the coil using high-pressure cleaners so as not to apply excessive pressure which could cause irreparable damage. Damage caused by cleaning with unsuitable chemical substances or excessively high water pressure will not be recognised under warranty.</b>
	<b>CAUTION: The aluminium fins are thin and sharp. Pay the utmost attention and use appropriate PPE to avoid cuts and abrasions. Cover your eyes and face appropriately to avoid squirting water and filth while blowing. Wear waterproof shoes or boots and clothing covering your entire body.</b>
	<b>For units installed in an aggressive atmosphere with a high rate of fouling, cleaning of the coil should be part of the routine maintenance programme. On this type of installation, all dust and particles deposited on the batteries must be removed as soon as possible by periodic cleaning in accordance with the above instructions.</b>

## 9.2 CLEANING OF EXTERNAL SURFACES

The sheets of the outer casing must be properly cleaned to avoid the accumulation of dust / dirt, preventing the onset of corrosion. The painting ensures resistance to atmospheric agents but it is good practice to make sure to remove any dirt present, cleaning the surfaces with neutral detergent and water, especially if the unit is installed in places with an aggressive atmosphere (high level of pollution, salt, etc).

### 9.2.1 Sensor calibration

It is mandatory to calibrate the sensor once every 12 months or at intervals as prescribed by the plant designer (and in any case not exceeding 12 months), so as to maintain the safety, measurement and detection functions of the refrigerant gas unaltered.

To determine the optimal calibration interval, it is suggested to carry out a series of functional checks on the zero point and on the sensitivity of the gas detector at specified intervals (more frequent in the first months after the installation of the machine), to assess that there are no alterations in its functionality.

Calibration must be carried out only by qualified personnel. Repairs and modifications carried out by unauthorized persons or those who do not comply with the manufacturer's specifications can severely alter the functionality of the component, resulting in an immediate termination of the void the warranty and certification of the sensor.

The periodic calibration consists in the definition of the zero point and the sensitivity of the sensor through the use of test gases at a well-defined concentration. In addition, it can be combined with other functional controls:



- Visual inspection.
- Check of the sensor response time.
- Check of fault and alarm relay status.

After the period required for sensor maintenance has expired, immediately contact an authorized service center that will take care of the operations described above.

## 10. DECOMMISSIONING

Once the unit has reached the end of its life cycle and needs to be replaced, the following operations are recommended:

- The refrigerant has to be recovered by trained personnel and sent to proper collection centres; according to the procedures indicated in Regulation No. 517/2014 on fluorinated greenhouse gases;
- Any antifreeze additives in the water circuit must be recovered and disposed of properly;
- The compressors' lubricating oil has to be collected and sent to proper collection centres;
- The electronic components, such as regulators, driver boards and inverters, must be disassembled and sent to proper collection centres;
- The structure and the different components, if unusable, must be scrapped and divided according to their nature; there is especially a good amount of copper and aluminium in the machine.

These operations allow easy material recovery and the recycling process, thus reducing the environmental impact in accordance with the provisions of Directive 2012/19 / EU on waste electrical and electronic equipment (RAEE).

The user is responsible for the proper disposal of this product, according to national regulations in the country of destination of the appliance. For more information, you should contact the Installation Company or local competent authority.

	<p><b>An incorrect decommissioning of the appliance may create serious environmental damage and endanger people's safety. Therefore, it is recommended that the unit be disposed only by authorised persons with technical training who have attended training courses acknowledged by the competent authorities.</b></p>
	<p><b>It is required to follow the same precautions described in the previous paragraphs.</b></p>
	<p><b>Pay special attention during disposal of the refrigerant gas.</b></p>
	<p><b>The illegal disposal of the product by the end user leads to the application of the penalties in accordance with the law in the country where the disposal takes place.</b></p>
	<p><b>The crossed-out bin symbol applied on the appliance indicates that the product, at the end of its useful life, must be collected separately from other solid/municipal waste. The units are manufactured in accordance with the EC directive on waste of electric/electronic equipment and the harmful effects of incorrect disposal are provided in the user/installer manual. The manufacturing company or its importer/retailer is available to respond to any requests for additional information.</b></p>

## 11. RESIDUAL RISKS

The residual risks related to handling, installation and normal operation of the unit are listed below. Any failure by the user and installer to comply with the instructions/indications in the manual (references to which are given in the table) will result in the continuation of these risks, which cannot be eliminated by the manufacturer, who has already taken all the necessary design precautions to ensure that each risk is reduced to a minimum.

Danger	Indication / Instruction	Residual risk	User / Activity				
			Operator			User	
			Transport phase	Installation phase	Maintenance phase	Unit interaction	Normal unit operation
Mechanical: crushing caused by the possible instability of the unit during handling.	The procedures for correct unit handling and installation are indicated on the user-installer manual under chapter 5, with indication of the center of gravity, of the lifting points and equipment. Protection devices use is also recommended as required by current regulations.	Failure by the installer to comply with the installation procedures.	X	X			



Danger	Indication / Instruction	Residual risk	User / Activity				
			Operator			User	
			Transport phase	Installation phase	Maintenance phase	Unit interaction	Normal unit operation
Mechanical: crushing caused by the possible instability of the unit.	The procedures for proper unit installation are indicated on user-installer manual under chapter 5.	Failure by the installer to comply with the installation procedures.		X	X		
Mechanical: Cutting / sectioning / shearing caused by the fan not protected against accidental contacts.	The user-installer manual under chapter 9 contains specific warnings, also relating to the routine maintenance phases.	Removal of the protective grille by the user or maintenance technician.			X	X	
Entanglement caused by the fan not protected against accidental contacts.	The user-installer manual under chapter 9 contains specific warnings, also relating to the routine maintenance phases.	Removal of the protection grid by the user or maintenance technician.			X	X	
Mechanical: cutting / abrasion due to contact with the heat exchange coil.	The user-installer manual under chapter 9 contains specific warnings to be taken into consideration when working near the battery.	Failure to observe the warnings in the manual and on the label.			X	X	
Mechanical: slipping / falling caused by ice / water near the unit as a result of water leaks.	In the user-installer manual under paragraph 5.8 is recommended to pay attention to the conveyance of the safety valve and in paragraph 5.4 there are indications regarding the surface on which the unit rests. During maintenance, the use of PPE and the possible removal of all water residues near the machine after intervention is recommended.	Failure to comply with the instructions given in the manual.			X	X	
Mechanical: cut / abrasion caused by the presence of edges on the external casing of the machine and / or screws protruding both outside and inside the unit.	The correct maintenance procedures are indicated in the user-installer manual under chapter 9. Paragraph 4.2 recommends the use of the necessary personal protective equipment.	Failure to comply with the procedures and / or failure to use PPE by the maintenance technician			X	X	
Mechanical: projection of parts or fluids caused by exceeding the operating pressure limits.	The correct maintenance procedures are indicated in the user-installer manual under chapter 9. Paragraph 4.2 recommends the use of the necessary personal protective equipment.	Simultaneous damage to both types of protection devices.			X	X	
Mechanical: Entrapment due to closure of access panel with person inside.	The unit has a square floor plan and the interior is clearly visible.	Lack of control at closure, but this is considered improbable considering the plan and dimensions of the unit.			X		
Mechanical: Pressure, impact due to the open door accidentally moving.	Paragraph 4.2 recommends the use of appropriate personal protective equipment. And in paragraph 5.7 the risk to the operator is highlighted.	Non-observance of procedures by the maintenance technician or behaviour			X		
Mechanical: Cut/abrasion caused by the fins of the inverter heat sinks.	Section 4.2 recommends the use of appropriate personal protective equipment.	Failure of the maintenance technician to use PPE.			X		
Electrical: electrocution / shock / burn caused by contact with live parts.	The safety measures to be taken in case of maintenance, cleaning or checking of the unit are indicated in the user-installer manual under chapter 9. Any intervention must only be carried out by qualified personnel and with the machine switched off.	Failure to comply with the procedures by the maintenance technician or irresponsible behavior by the user.			X	X	
Electrical: effects on medical implants (pacemakers) caused by electromagnetic phenomena.	The user-installer manual in chapter 3 states the prohibition of direct interaction with the unit by people with electrically controlled medical devices, such as pacemakers. It is recommended to keep a distance from the installation site of the unit as indicated by the medical system used.	Failure to comply with the instructions given in the manual.			X	X	



Danger	Indication / Instruction	Residual risk	User / Activity				
			Operator			User	
			Transport phase	Installation phase	Maintenance phase	Unit interaction	Normal unit operation
Electrical: Fire causes short circuit or electric arcs.	The correct installation procedures are indicated in the user-installer manual under chapter 5. In case of maintenance, the use of the necessary personal protective equipment is recommended.	The possibility of triggering cannot be eliminated but its probability of occurrence is reduced. With the measures taken, the spread of the fire is reduced.			X	X	
Electrical: projection of particles and emission of harmful chemicals as a result of electrical overload.	Chapter 9 in the user-installer manual indicates that maintenance must be carried out with machine off.	Failure to comply with the instructions given in the manual.			X	X	
Thermic: burning / scalding from contact with hot surfaces.	The user-installer manual in chapter 9 indicates the safety measures to be adopted in case of maintenance, cleaning or control of the unit and the personal protective equipment to be equipped.	Failure to comply with the procedures and / or failure to use PPE by the maintenance technician.			X	X	
Caused by noise: Discomfort caused by the noise of the unit during operation.	In the user-installer manual in chapter 5 suspended installation is prohibited and an environmental impact assessment is requested based on the installation area of the unit, even in the case of installation close to workers.	Failure to observe the actions recommended in the manual and the study of the environmental impact.					X
Cause by vibration: Discomfort caused by unit vibrations during operation.	In the user-installer manual under chapter 5 suspended installation is prohibited and the use of anti-vibration mounts is recommended.	Failure to observe the actions recommended in the manual and the study of the environmental impact.					X
Caused by radiation: electromagnetic radiation that the unit generates during operation.	-	No one.					X
Generated by materials / substances: infections caused by bacteria potentially present in the carrier fluid (technical water).	The use of personal protective equipment is recommended in the user-installer manual under paragraph 4.2. The safety data sheet for the refrigerant (paragraph 4.4) and specific warnings (paragraph 4.5) are also shown.	Failure to comply with the procedures by the maintenance technician.			X	X	
Generated by materials / substances: fire / explosion causes gas classified as slightly flammable.	The user-installer manual under chapter 5 contains specific indications about unit installation place and protection devices.	Failure to comply with the indications relating to the place of installation and adequate maintenance procedures			X		X
Generated by materials / substances: infections caused by bacteria potentially present in the carrier fluid (technical water).	The permitted uses of the unit are listed in the user-installer manual under chapter 3.	Failure to comply with the instructions given in the manual.			X		X
Generated by materials / substances: burn caused by the presence of oil inside the refrigeration circuit, triggered by a flame welding torch.	The use of personal protective equipment is recommended in the user-installer manual under paragraph 4.2. Under chapter 9 it is advisable, in the case of maintenance that involves desoldering the tubes, to proceed with cutting them, as the flame of the torch for desoldering triggers any oil present.	Failure to comply with the instructions given in the manual.			X		
Generated by materials / substances: burn / scald from escaping refrigerant.	The safety measures to be adopted in case of maintenance, cleaning or control of the unit and the personal protective equipment to be equipped are indicated in the user-installer manual under chapter 9.	Failure to comply with the instructions given in the manual.			X		X
Generated by materials / substances: pollution due to inappropriate disposal.	The instructions for correct disposal are given in the user-installer manual under chapter 10.	Failure to comply with the instructions given in the manual.					



Danger	Indication / Instruction	Residual risk	User / Activity				
			Operator			User	
			Transport phase	Installation phase	Maintenance phase	Unit interaction	Normal unit operation
Ergonomic: fatigue / musculoskeletal disorders caused by exertion during maintenance / installation.	Under paragraph 4.1, the user-installer manual recommends compliance with current regulations (international and local) regarding workers health and safety. During maintenance, it is advisable to keep a posture that does not cause fatigue and to check the weight of the component before proceeding with its handling (paragraph 9.3).	Failure to comply with the instructions given in the manual.		X	X		
Generated by unit use environment: Slipping / falling caused by ice / water near the unit due to condensate drain / defrost.	Under paragraph 5.8.5 the user-installer manual indicates about condensate drain system, recommending that you pay attention to the danger of slipping.	Failure to comply with the instructions given in the manual.			X	X	
Generated by unit use environment: unexpected events as a result of malfunctions due to water / snow / humidity.	In the user-installer manual under chapter 9 it is recommended to pay attention to the correct tightening of the cable gland designed for the passage of the electric power cable and to the reassembly of all the sheets, in particular those of the electrical panel, in order to maintain the degree of declared protection.	Failure to comply with the procedures by the maintenance technician.			X	X	
Generated by unit use environment: lightning that can potentially hit the unit.	In the user-installer manual under chapter 9 it is recommended to carry out maintenance only in weather conditions suitable for the operations envisaged. It is also indicated that the installation site must be sufficiently far from lightning rods or objects that could attract the lightning (par. 5.3). The unit must be electrically connected to a system that complies with the regulations in force.	Failure to comply with the instructions given in the manual.			X	X	
Generated by unit use environment: electromagnetic disturbances caused by interference between devices placed near the machine and the machine itself.	In the user-installer manual under paragraph 5.9 is recommended to power the unit via a dedicated line and protections. It is also recommended to use an independent cable duct in order to remove the possibility of interaction with other devices.	Failure to comply with the recommendations regarding the electrical system.					X
Generated by unit use environment: possibility of breakage of components / supports caused by corrosion and oxidation.	The user-installer manual under chapter 9 contains specific warnings on maintenance and cleaning to be carried out on the surfaces of the sheets and heat exchange coils. The technical bulletin provides advice on the treatments to choose based on the environmental conditions.	Failure to comply with cleaning and maintenance and / or incorrect assessment of the atmospheric agents that characterize the installation site.			X	X	
Generated by the operating environment of the machine: slipping/falling caused by ice/snow on the base of the unit.	In the user-installer manual in section 4.2 the use of personal protective equipment is recommended. In the user-installer manual in chapter 9 it is recommended that maintenance should only be carried out in weather conditions suitable for the intended operations.	Failure to comply with cleaning and maintenance and / or incorrect assessment of the atmospheric agents that characterize the installation site.			X		



Danger	Indication / Instruction	Residual risk	User / Activity				
			Operator			User	
			Transport phase	Installation phase	Maintenance phase	Unit interaction	Normal unit operation
Generated by the operating environment of the machine: Heat stroke due to high temperatures inside the machine if it is hot, the unit is working in a chiller and is located in a particularly sunny area.	In the user-installer manual in section 4.2 the use of personal protective equipment is recommended. In the user-installer manual in chapter 9 it is recommended that maintenance should only be carried out in weather conditions suitable for the intended operations.	Failure to comply with cleaning and maintenance and / or incorrect assessment of the atmospheric agents that characterize the installation site.			X		



## 12. TECHNICAL DATA

### 12.1 TECHNICAL DATA SHEET UNIT

Performance referring to the following conditions, according to standard UNI EN 14511:2022:

- (1) Cooling: outdoor air temperature 35°C; in/out water temperature 12/7°C.
  - (2) Cooling: outdoor air temperature 35°C; in/out water temperature 23/18°C.
  - (3) Heating: outdoor air temperature 7°C db 6°C db; in/out water temp 30/35°C.
  - (4) Heating: outdoor air temperature 7°C db 6°C db; in/out water temp 47/55°C.
  - (5) Cooling: low temperature, variable output, fixed flow.
  - (6) Heating: average climatic conditions;  $T_{\text{ext}} = -7^{\circ}\text{C}$ ; low temperature, variable output, fixed flow.
  - (7) Indicative data subject to changes. For the correct value, always refer to the technical label on the unit.
  - (8) The volume indicated refers to the total needed, the designer must satisfy this by considering the quantity already inside the unit depending on the hydronic kit chosen (please check this value in the data sheet).
  - (9) Sound power: mode (1); value determined on the basis of measurements made in accordance with UNI EN ISO 9614-1.
  - (10) Sound pressure: value calculated from the sound power level in condition (9) using the standard UNI EN ISO 3744:2010.
  - (11) Sound mode: heating mode according to EN 12102:2022 Annex A; value determined on the basis of measurements made in accordance with UNI EN ISO 9614-1, in compliance with Eurovent certification requirements.
  - (12) Heating: outdoor air temperature 7 °C b.s. 6 °C b.u.; inlet/outlet water temp. 55/65 °C.
- (\*) activating the maximum Hz function.

**N.B. performance data are indicative and are subject to change. Furthermore the performance declared in points (1), (2), (3) and (4) is intended to refer to instantaneous power according to EN 14511:2022. The value declared in point (5) and (6) is determined according to UNI EN 14825:20.**



TECHNICAL CHARACTERISTICS		Unit	SHP290		
			40 kW	50 kW	
Cooling	Cooling capacity (1)	kW	28,9	34,1	
	Power input (1)	kW	9,20	11,0	
	E.E.R. (1)	W/W	3,14	3,10	
	Cooling capacity (2)	kW	34,5	37,0	
	Power input (2)	kW	8,10	8,53	
	E.E.R. (2)	W/W	4,26	4,34	
	SEER (5)	W/W	4,86	4,80	
	Water flow (1)	L/s	1,38	1,63	
	Pressure drop on hydronic circuit side (1)	kPa	24	26	
Heating	Heating capacity (3)	kW	40,1	50,0	
	Power input (3)	kW	9,8	11,9	
	C.O.P. (3)	W/W	4,10	4,20	
	Heating capacity (4)	kW	38,0	47,9	
	Power input (4)	kW	13,1	16,5	
	C.O.P. (4)	W/W	2,90	2,90	
	Heating capacity (12)	kW	38,4	45,8	
	Power input (12)	kW	16,0	18,8	
	C.O.P. (12)	W/W	2,40	2,44	
	SCOP (6)	W/W	4,09	4,20	
	Water flow (4)	L/s	1,14	1,43	
		Pressure drop on hydronic circuit side (4)	kPa	20	26
		Energy efficiency - water 35°C / 55°C	Class	A++ / A++	A++ / A++
Compressor	Type		Scroll DC Inverter		
	Quantity		2	2	
	Refrigerant oil (type)		PZ46M	PZ46M	
	Refrigerant oil (quantity)	mL	1800	1800	
	Refrigerant circuits		1	0	
Refrigerant	Type		R290		
	Refrigerant quantity (7)	kg	3,15	3,50	
	Refrigerant quantity in tonnes of CO2 equivalent (7)	ton	0,009	0,011	
	Design pressure (high/low) heat pump mode	bar	30,3 / 1,7		
	Design pressure (high/low) chiller mode	bar	30,3 / 0,7		
External zone fans	Type		EC		
	Quantity	Quantity	1		
	Nominal power (1)	kW	0,62	0,69	
	Maximum power input	kW	1,95	1,95	
	Maximum current input	A	3,3	3,3	
	Nominal air flow	m³/h	17080	18490	
Internal heat exchanger	Internal heat exchanger type		A piastre / BPHE		
	N° internal heat exchanger		1	1	
	Water content	L	2,80	3,48	
Hydronic circuit	Water content of the hydronic circuit	L	4,5	5,2	
	Maximum pressure hydronic kit (safety valve setting)	bar	6	6	
	Hydraulic connections	inch	1" 1/2 (DN 40)	1" 1/2 (DN 40)	
	Minimum water volume (8)	L	365	415	
Noise	Sound power Lw (9)	dB(A)	82	83	
	Sound power level Lw configuration SL (9)	dB(A)	81	82	
	Sound power level Lw configuration SSL (9)	dB(A)	80	81	
	Sound pressure Lp1 (10) at 1 m	dB(A)	64/64/64	65/65/65	
	Sound power level Lw (11)	dB(A)	74	75	
Electrical data	Power supply		400V/3P+N+T/50Hz		
	Maximum power input	kW	23	27	
	Maximum current input	A	37	44	
	Max. power input with antifreeze kit	kW	23	27	
	Max. current input with antifreeze kit	A	38	45	



TECHNICAL CHARACTERISTICS		Unit	SHP290	
			40 kW	50 kW
Cooling	Cooling capacity (1)	kW	28,8	34,1
	Power input (1)	kW	9,29	11,0
	E.E.R. (1)	W/W	3,10	3,10
	Cooling capacity (2)	kW	34,5	37,0
	Power input (2)	kW	8,16	8,53
	E.E.R. (2)	W/W	4,23	4,34
	SEER (5)	W/W	4,89	4,81
	Water flow (1)	L/s	1,38	1,63
Heating	Heating capacity (3)	kW	40,0	50,1
	Power input (3)	kW	9,76	11,9
	C.O.P. (3)	W/W	4,10	4,21
	Heating capacity (4)	kW	38,1	47,9
	Power input (4)	kW	13,4	16,5
	C.O.P. (4)	W/W	2,84	2,90
	Heating capacity (12)	kW	38,5	45,9
	Power input (12)	kW	16,3	18,9
	C.O.P. (12)	W/W	2,36	2,43
	SCOP (6)	W/W	4,10	4,20
	Water flow (4)	L/s	1,14	1,43
	Energy efficiency - water 35°C / 55°C	Class	A++ / A++	A++ / A++
	Compressor	Type		Scroll DC Inverter
Quantity			2	2
Refrigerant oil (type)			PZ46M	PZ46M
Refrigerant oil (quantity)		mL	1800	1800
Refrigerant circuits			1	0
Refrigerant	Type		R290	
	Refrigerant quantity (7)	kg	3,15	3,50
	Refrigerant quantity in tonnes of CO2 equivalent (7)	ton	0,009	0,011
	Design pressure (high/low) heat pump mode	bar	30,3 / 1,7	
	Design pressure (high/low) chiller mode	bar	30,3 / 0,7	
External zone fans	Type		EC	
	Number		1	
	Nominal power (1)	kW	0,62	0,68
	Maximum power input	kW	1,95	1,95
	Maximum current input	A	3,3	3,3
	Nominal air flow	m³/h	16680	18020
Internal heat exchanger	Internal heat exchanger type		A pastre / BPHE	
	N° internal heat exchanger		1	1
Hydraulic circuit	Water content	L	2,80	3,48
	Useful prevalence (1) (**)	kPa	139	124
	Useful prevalence (4) (**)	kPa	153	144
	Water content of the hydronic circuit	L	6,5	7,0
	Maximum pressure hydronic kit (safety valve setting)	bar	6	6
	Hydraulic connections	inch	1" 1/2 (DN 40)	1" 1/2 (DN 40)
	Minimum water volume (8)	L	365	415
	Nominal pump power (1)	kW	0,75	0,75
	Maximum pump power input	kW	1,04	1,04
Noise	Maximum pump current input	A	1,86	1,86
	Sound power level Lw (9)	dB(A)	82	83
	Sound power level Lw configuration SL (9)	dB(A)	81	82
	Sound power level Lw configuration SSL (9)	dB(A)	80	81
	Sound pressure Lp1 (10) at 1 m	dB(A)	64/64/64	65/65/65
Electrical data	Sound power level Lw (11)	dB(A)	74	75
	Power supply		400V/3P+N+T/50Hz	
	Maximum power input	kW	23	27
	Maximum current input	A	37	44
	Max. power input with antifreeze kit	kW	23	27
Max. current input with antifreeze kit	A	38	45	



TECHNICAL CHARACTERISTICS		Unit	SHP290		
			40 kW	50 kW	
Cooling	Cooling capacity (1)	kW	28,4	33,7	
	Power input (1)	kW	9,73	11,4	
	E.E.R. (1)	W/W	2,92	2,96	
	Cooling capacity (2)	kW	34,0	36,6	
	Power input (2)	kW	8,52	8,99	
	E.E.R. (2)	W/W	3,99	4,07	
	SEER (5)	W/W	4,21	4,20	
Heating	Water flow (1)	L/s	1,36	1,61	
	Heating capacity (3)	kW	40,4	50,1	
	Power input (3)	kW	10,2	12,2	
	C.O.P. (3)	W/W	3,96	4,11	
	Heating capacity (4)	kW	38,4	48,3	
	Power input (4)	kW	13,8	17,1	
	C.O.P. (4)	W/W	2,78	2,82	
	Heating capacity (12)	kW	38,9	46,2	
	Power input (12)	kW	16,7	19,5	
	C.O.P. (12)	W/W	2,33	2,37	
	SCOP (6)	W/W	3,84	3,89	
	Water flow (4)	L/s	1,15	1,44	
	Energy efficiency - water 35°C / 55°C	Class	A++ / A+	A++ / A+	
	Compressor	Type		Scroll DC Inverter	
		Quantity		2	2
Refrigerant oil (type)			PZ46M	PZ46M	
Refrigerant oil (quantity)		mL	1800	1800	
Refrigerant circuits			1	0	
Refrigerant	Type		R290		
	Refrigerant quantity (7)	kg	3,15	3,50	
	Refrigerant quantity in tonnes of CO2 equivalent (7)	ton	0,009	0,011	
	Design pressure (high/low) heat pump mode	bar	30,3 / 1,7		
	Design pressure (high/low) chiller mode	bar	30,3 / 0,7		
External zone fans	Type		EC		
	Number		1		
	Nominal power (1)	kW	0,62	0,68	
	Maximum power input	kW	1,95	1,95	
	Maximum current input	A	3,3	3,3	
	Nominal air flow	m³/h	17070	18480	
Internal heat exchanger	Internal heat exchanger type		A piastre / BPHE		
	N° internal heat exchanger		1	1	
Hydraulic circuit	Water content	L	2,80	3,48	
	Useful prevalence (1) (**)	kPa	438	418	
	Useful prevalence (4) (**)	kPa	450	438	
	Water content of the hydronic circuit	L	6,5	7,0	
	Maximum pressure hydronic kit (safety valve setting)	bar	6	6	
	Hydraulic connections	inch	1" 1/2 (DN 40)	1" 1/2 (DN 40)	
	Minimum water volume (8)	L	365	415	
	Nominal pump power (1)	kW	2,20	2,20	
	Maximum pump power input	kW	2,20	2,20	
Noise	Maximum pump current input	A	4,15	4,15	
	Sound power level Lw (9)	dB(A)	82	83	
	Sound power level Lw configuration SL (9)	dB(A)	81	82	
	Sound power level Lw configuration SSL (9)	dB(A)	80	81	
	Sound pressure Lp1 (10) at 1 m	dB(A)	64/64/64	65/65/65	
Electrical data	Sound power level Lw (11)	dB(A)	74	75	
	Power supply		400V/3P+N+T/50Hz		
	Maximum power input	kW	23	27	
	Maximum current input	A	37	44	
	Max. power input with antifreeze kit	kW	23	27	
Max. current input with antifreeze kit	A	38	45		



## 12.2 UNIT AND AUXILIARY ELECTRICAL DATA

Unit power supply	V/~/Hz	400/3PH+PE/50
On board controller circuit	V/~/Hz	12/1/50
Remote controller circuit	V/~/Hz	12/1/50
Fan power supply	V/~/Hz	400/3PH+PE/50

**NOTE:** The electrical data are subject to change due to updates. It is therefore always necessary to refer to the technical specifications label applied on the unit.

## 13. OPERATING LIMITS

### 13.1 EVAPORATOR WATER FLOW RATE

The nominal water flow rate refers to a 5°C temperature difference between the evaporator inlet and outlet. The maximum permitted flow rate features a 3°C temperature difference while the minimum one has an 10°C temperature difference at the nominal conditions as shown in the technical sheet.



**Insufficient water flow rates can cause excessively low evaporation temperatures causing the safety devices to trigger and stopping the unit and, in some extreme cases, forming ice in the evaporator and resulting in serious failures to the cooling circuit.**

For greater details, we have attached a table below with the minimum flow rates for the plate heat exchanger to guarantee proper operation according to the model (please note: the water flow switch is applied to protect against failed triggering of the antifreeze probe due to the lack of flow but does not guarantee the minimum water flow rate required for correct operation of the unit).

SHP290	Heat pump	
	40 kW	50 kW
Minimum water flow to be assured in chiller mode (condition (1) technical sheet) [l/s]	0,69	0,81
Maximum water flow to be assured in chiller mode (condition (1) technical sheet) [l/s]	2,29	2,72
Flow switch intervention rate – decreasing flow* [l/s]	0,56	0,77
Flow switch intervention rate - increasing flow* [l/s]	0,58	0,80

\* When the flow rate drops below the indicated limit (flow switch minimum water flow rate) the flow switch issues an alarm, which may be reset only upon reaching the maximum indicated flow rate.



**Pay attention to the pressure levels of the hydraulic system: too low values can cause malfunctioning of the unit.**

It is good practice to vent the system periodically, especially if very high temperature differences between the inlet and outlet on the water side are read, as this could be a symptom of the presence of air bubbles in the circuit that reduce the available water flow rate.



**WARNING:** In the event of a micro-leakage of propane in the water, this could be released into the environment when venting the system. Take appropriate safety precautions such as preferably venting in an open environment and not carrying any appliances/devices/equipment that could generate a spark.

### 13.2 COLD WATER PRODUCTION (SUMMER MODE)

A minimum temperature of 5°C is allowed at the evaporator outlet for standard units. For BT units (low temperature) minimum temperature is -8°C. In this case glycol water must be used. A maximum temperature of 20°C can be maintained at the evaporator outlet in steady-state operation.

### 13.3 HOT WATER PRODUCTION (WINTER MODE)

Once the system is just right, it is necessary to ensure that the flow temperature is always above 20°C\*\*: lower values, not due to transient phases or reaching steady-state, can cause system failures and could possibly break the compressor. The maximum outlet water temperature must not exceed 78°C.

Temperatures higher than those indicated, especially in conjunction with low water flow rates, could lead to malfunctioning of the unit, or in the most critical cases safety devices could intervene.

### 13.4 AMBIENT AIR TEMPERATURE AND SUMMERY TABLE

The units are designed and built to operate in summer mode, with condensation control, at outdoor air temperatures between +10°C and +46°C. In heat pump mode, the allowed temperature range of the outdoor air is from -20°C to 45°C depending on the outlet water temperature as shown in the table below.





## Operating limits

Water chiller mode		
Ambient temperature	Minimum +10 °C	Maximum +46 °C
Outlet water temperature	Minimum +5 °C	Maximum +20 °C

Heat pump mode		
Ambient temperature	Minimum -20 °C	Maximum +20 °C
Outlet water temperature	Minimum +20 °C **	Maximum +78 °C **

Heat pump mode for domestic hot water		
Ambient temperature with water at +60 °C maximum	Minimum -20 °C	Maximum +45 °C
Ambient temperature with water at +65 °C maximum	Minimum -14 °C	Maximum +45 °C
Ambient temperature with water at +78 °C maximum	Minimum 0°C	Maximum +38 °C

\*\* The minimum and maximum permissible temperatures depend on the outside air temperature. Set the desired value considering the envelope.

Limit of installability	
Maximum altitude	2000 m s.l.m.
Refer to Chapter 5.4 del BTE02070100000 for reduction of yield as a function of altitude.	

Below are the graphed operating limits for heating, cooling and domestic hot water production. Please note that operating the unit outside the operating limits given causes blocking alarms that lead to the product shutting down, with possible damage to components and/or safety devices.

### HEAT PUMP MODE

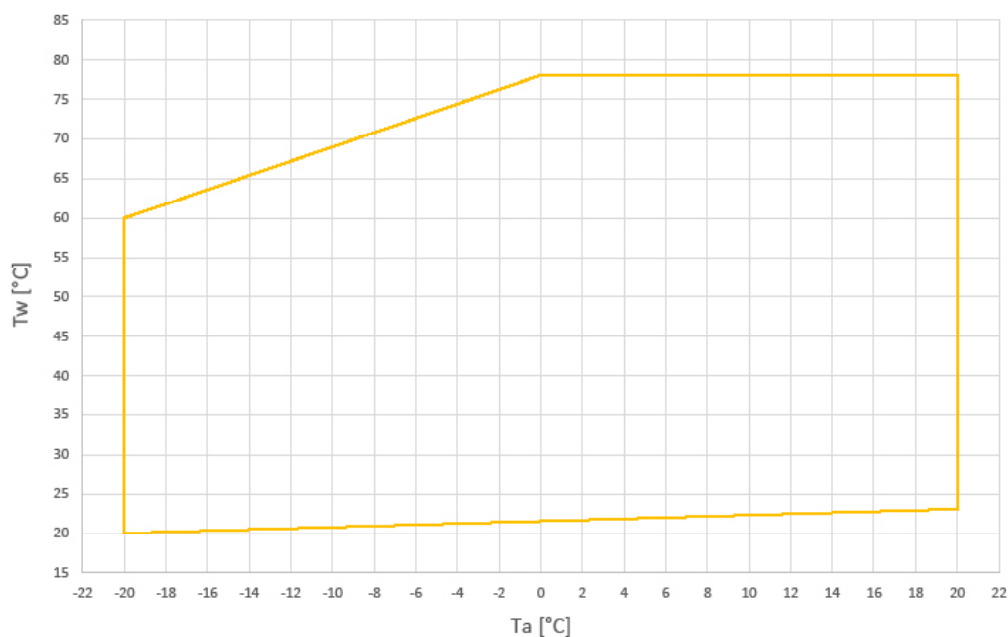



## COOLING MODE

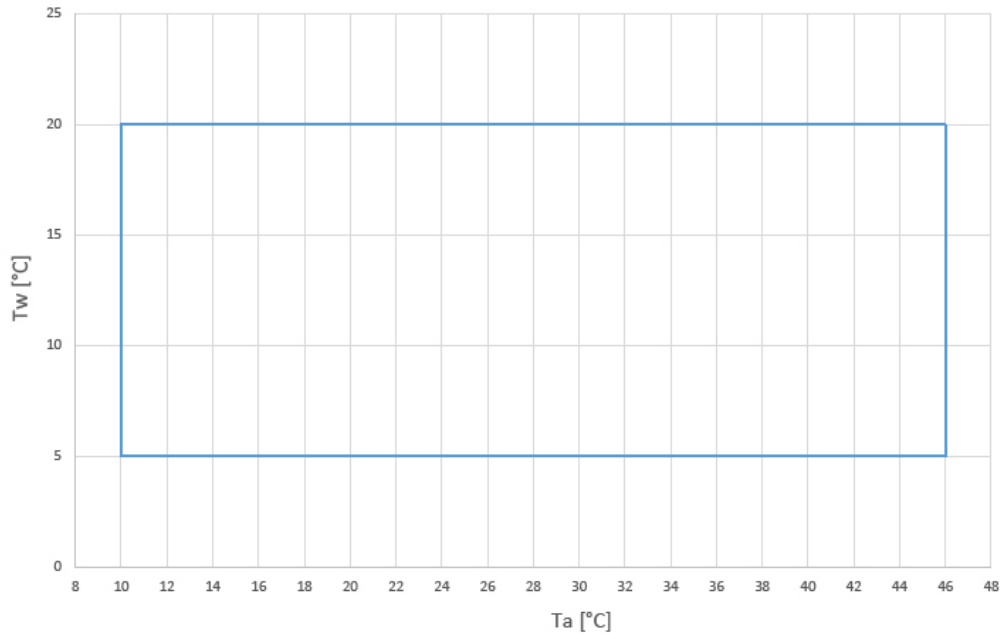

## DOMESTIC HOT WATER MODE

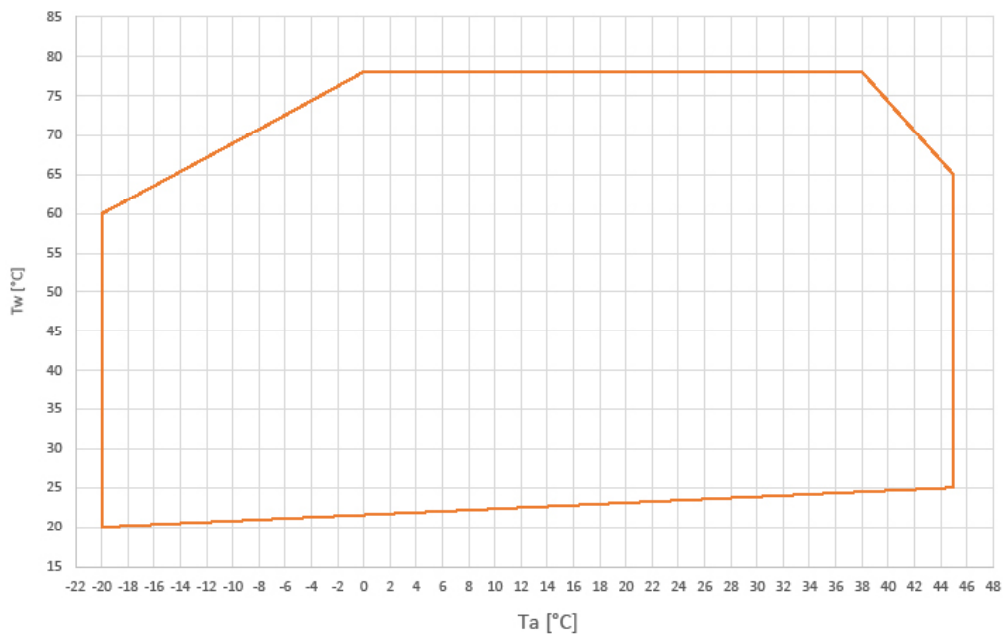

Tw = water temperature  
Ta = air temperature  
A = maximum Hz functionality has no effect



## 14. USER INTERFACE - CONTROLLER

The unit includes a display placed underneath a hinged polycarbonate transparent door with a protection rating of IP67. The interface has a part with variable text and a series of icons identifying operation of the unit as shown in the table below.



Cooling mode led: led ON if unit is in COOL or COOL+SAN mode.	
Heating mode led: led ON if unit is in HEAT or HEAT+SAN mode.	
Pump led: led ON if pump running.	
Alarm led: led ON if an alarm is triggered.	
Defrosting led: flashes to enter defrosting mode, lit when defrosting is in progress.	
Compressor led: flashes if the compressor is starting, is ON if the compressor is active.	
Domestic hot water led: flashes if domestic hot water production is in progress, is ON if COOL+SAN or HEAT+SAN mode is selected and domestic hot water production is not in progress.	
Led KA resistors: is lit if the antifreeze resistors are active.	

The buttons have the specific function described below:

Select the operating mode and manually reset any alarms. Each time you press the key you have the following sequence: OFF -> COOL -> COOL+SAN* -> HEAT -> HEAT+SAN* -> OFF (*= if sanitary mode is enabled) While setting the parameters, this key has the function of sending BACK by one level.	
Allows you to enter the selected menu to view sub-folders or to set a value (e.g. summer, winter and DHW set-points or various parameters).	
The UP key is used to move to a higher menu or to increase the value of a parameter.	



The DOWN key is used to move to a lower menu or to decrease the value of a parameter.



In standard operation, the display shows the water outlet temperature in tenths of Celsius degrees or the alarm code if at least one is active. If several alarms are triggered, the first one is displayed while the second one will be displayed as soon as the first one is reset. In menu mode, the display depends on the current position.

## 14.1 MENU

The following are the main features for navigating the menus, especially describing functions which are not obvious. The main menu has the following items:

MENU	LABEL	LEVEL	OTHER CONDITIONS
Setpoint	Set	User	Not accessible if connected to Hi-TV415
Password	PSS	User	---
Alarms	Err	User	Only if active alarms
Probes	tP	Installer	---
Digital inputs	Id	Installer	---
Parameter	Par	Installer	---
Hours of operation	oHr	Installer	---
Alarm log	Hist	Installer	Only if the log contains data
Firmware Version	Fir	Installer	---
USB	USB	Installer	Only with pen drive with relevant update files

The PSS menu is accessed to enter the service password and to enable access with a higher user permission. When you have exited the menus, the password must be entered once again to re-enter.

## 14.2 SETPOINT MENU

The various setpoints can be viewed and edited.

Set	DESCRIPTION	DEFAULT	RANGE	UNIT
<b>Coo</b>	First summer setpoint	7.0	5 ÷ Coo2	°C
<b>Hea</b>	First winter setpoint	45.0	Hea2 ÷ 60	°C
<b>*San</b>	Sanitary setpoint	48.0	25 ÷ 60	°C
<b>*San2</b>	Second Sanitary setpoint	48.0	25 ÷ 60	°C
<b>Coo2</b>	Second Summer setpoint	18.0	Coo ÷ 25	°C
<b>Hea2</b>	Second Winter setpoint	35.0	25 ÷ Hea	°C

(\*) If the DHW function is enabled

(\*\*) If Gi module is included, access is only possible with installer password.

## 14.3 ALARM MENU [ERR]

The menu only appears if there are active alarms and lists the errors present. In the case of a multi-circuit machine, the alarms are subdivided by circuit (label ALCx grants access to the alarms of circuit number x).









**SAPPHIRE HEAT SOLUTIONS**  
5 Howard Road, Eaton Socon,  
Cams, PE19 8ET  
01480 477066  
[sales@sapphireheatsolutions.co.uk](mailto:sales@sapphireheatsolutions.co.uk)  
[www.sapphireheatsolutions.co.uk](http://www.sapphireheatsolutions.co.uk)